

Code No. LIT-12012114

Installation Manual

Effective July 2015

JC-VSD Factory Packaged (FP) Series II
drive frames 4–8, Type 1 and 3R



Disclaimer of warranties and limitation of liability

The product discussed in this literature is subject to terms and conditions outlined in Johnson Control Inc. selling policies. The sole source governing the rights and remedies of any purchaser of this equipment is the relevant Johnson Control Inc. selling policy.

NO WARRANTIES, EXPRESS OR IMPLIED, INCLUDING WARRANTIES OF FITNESS FOR A PARTICULAR PURPOSE OR MERCHANTABILITY, OR WARRANTIES ARISING FROM COURSE OF DEALING OR USAGE OF TRADE, ARE MADE REGARDING THE INFORMATION, RECOMMENDATIONS AND DESCRIPTIONS CONTAINED HEREIN

In no event will Johnson Control Inc. be responsible to the purchaser or user in contract, in tort (including negligence), strict liability or otherwise for any special, indirect, incidental or consequential damage or loss whatsoever, including but not limited to damage or loss of use of equipment, plant or power system, cost of capital, loss of power, additional expenses in the use of existing power facilities, or claims against the purchaser or user by its customers resulting from the use of the information, recommendations and descriptions contained herein. The information contained in this manual is subject to change without notice.

Cover Photo: Johnson Controls variable speed drives

Safety

Read and follow all safety information shown in the JC-VSD Series II Installation Manual LIT-12011775.

Table of contents

SAFETY

Definitions and symbols	v
Hazardous high voltage	v
Warnings and cautions	v

GENERAL INFORMATION

Catalog/style numbering	1
Identification	2

COMPONENT DIAGRAMS

IntelliPass and IntelliDisconnect—typical component locations	3
---	---

STANDARD FACTORY WIRED COMPONENTS

Drive isolation fuses	8
Manual bypass switch	9
Space heater	10
Plug-in options	11
Auxiliary contacts (bypass only)	11
High temperature option	12

DIMENSIONS AND MOUNTING

WIRING

Wiring schematic	25
Conduit plates	31
Input power wiring	31
Motor wiring	32
Ground wiring	33
Control wiring	33

INITIAL STARTUP

IntelliDisconnect operation (starting/stopping of the motor)	34
IntelliPass operation (starting/stopping of the motor)	34
Switch operation	34
SA bus operation and setup	39

INTELLIPASS/INTELLIDISCONNECT TECHNICAL INFORMATION

Technical information	42
-----------------------------	----

ADDITIONAL HELP

Website address	43
Johnson Controls product sales operation	43

List of figures

Figure 1. JC-VSD FP Series II master product part number matrix— IntelliPass/IntelliDisconnect	1
Figure 2. JC-VSD FP Series II IntelliPass/IntelliDisconnect carton label	2
Figure 3. JC-VSD FP Series II IntelliPass/IntelliDisconnect nameplate	2
Figure 4. Type 1 IntelliDisconnect	3
Figure 5. Type 1 IntelliPass	4
Figure 6. Type 3R IntelliDisconnect	5
Figure 7. Type 3R IntelliPass	6
Figure 8. Type 1 Micro Disconnect	7
Figure 9. Fused disconnect	8
Figure 10. Door 3-position switches	9
Figure 11. Larger framed bypass contactor	9
Figure 12. Lower framed bypass contactor	9
Figure 13. Option PCB cards	12
Figure 14. Type 1 IntelliDisconnect dimensions	15
Figure 15. Type 1 IntelliDisconnect knockout dimensions	16
Figure 16. Type 1 IntelliPass dimensions	17
Figure 17. Type 1 IntelliPass knockout dimensions	18
Figure 18. Type 3R IntelliDisconnect dimensions	19
Figure 19. Type 3R IntelliDisconnect knockout dimensions	20
Figure 20. Type 3R IntelliPass dimensions	21
Figure 21. Type 3R IntelliPass knockout dimensions	22
Figure 22. Type 1 Micro Disconnect dimensions	23
Figure 23. Type 1 Micro Disconnect knockout dimensions	24
Figure 24. Type 1 IntelliDisconnect	26
Figure 25. Type 1 IntelliPass	27
Figure 26. Type 3R IntelliDisconnect	28
Figure 27. Type 3R IntelliPass	29
Figure 28. Type 1 Micro Disconnect	30
Figure 29. Lower frame incoming lines	31
Figure 30. Larger frame incoming lines	31
Figure 31. IntelliDisconnect motor wiring	32
Figure 32. IntelliPass motor wiring	32
Figure 33. Typical ground stud and label	33
Figure 34. Terminal block access	33
Figure 35. Startup Wizard prompt	34
Figure 36. Enable bypass for IntelliPass models	34
Figure 37. Disable bypass for IntelliPass models	34
Figure 38. Keypad shown in drive mode	35
Figure 39. Keypad shown in bypass mode	35
Figure 40. Keypad with bypass and drive mode option	36
Figure 41. Keypad shown in run mode	36
Figure 42. Keypad already in bypass mode	36
Figure 43. Parameter menu for automatic reset	37
Figure 44. Menu selecting auto bypass	37
Figure 45. Menu selecting reset/bypass	37

List of figures, continued

Figure 46. Displaying going into auto bypass after fault	37
Figure 47. Hand/Off/Auto parameter	38
Figure 48. Off menu selection	38
Figure 49. Monitoring menu in STOP mode	38
Figure 50. JC-VSD Series II drive SA bus interface card VS-XXM-CS	39

List of tables

Table 1. hp rating and fuse rating (A)	8
Table 2. Space heater	10
Table 3. Auxiliary contacts (bypass only)	11
Table 4. Option PCB cards	12
Table 5. Enclosure size and frame size based on voltage and horsepower (208/230 V)	13
Table 6. Enclosure size and frame size based on voltage and horsepower (480 V)	14
Table 7. Type 1 Micro Disconnect	14
Table 8. Type 1 IntelliDisconnect dimensions	15
Table 9. Type 1 IntelliDisconnect knockout dimensions	16
Table 10. Type 1 IntelliPass dimensions	17
Table 11. Type 1 IntelliPass knockout dimensions	18
Table 12. Type 3R IntelliDisconnect dimensions	19
Table 13. Type 3R IntelliDisconnect knockout dimensions	20
Table 14. Type 3R IntelliPass dimensions	21
Table 15. Type 3R IntelliPass knockout dimensions	22
Table 16. Type 1 Micro Disconnect dimensions	23
Table 17. Type 1 Micro Disconnect knockout dimensions	24
Table 18. Input wiring	31
Table 19. Output wiring details—IntelliDisconnect	32
Table 20. Output wiring details—IntelliPass	32
Table 21. Terminal block designation	33
Table 22. SA bus setup	39
Table 23. Object list	41
Table 24. Short-circuit rating	42

Safety

Definitions and symbols

WARNING

This symbol indicates high voltage. It calls your attention to items or operations that could be dangerous to you and other persons operating this equipment. Read the message and follow the instructions carefully.



This symbol is the "Safety Alert Symbol." It occurs with either of two signal words: CAUTION or WARNING, as described below.

WARNING

Indicates a potentially hazardous situation which, if not avoided, can result in serious injury or death.

CAUTION

Indicates a potentially hazardous situation which, if not avoided, can result in minor to moderate injury, or serious damage to the product. The situation described in the CAUTION may, if not avoided, lead to serious results. Important safety measures are described in CAUTION (as well as WARNING).

Hazardous high voltage

WARNING

Motor control equipment and electronic controllers are connected to hazardous line voltages. When servicing drives and electronic controllers, there may be exposed components with housings or protrusions at or above line potential. Extreme care should be taken to protect against shock.

Stand on an insulating pad and make it a habit to use only one hand when checking components. Always work with another person in case an emergency occurs. Disconnect power before checking controllers or performing maintenance. Be sure equipment is properly grounded. Wear safety glasses whenever working on electronic controllers or rotating machinery.

Warnings and cautions

This manual contains clearly marked cautions and warnings which are intended for your personal safety and to avoid any unintentional damage to the product or connected appliances.

Please read the information included in cautions and warnings carefully.

General information

This document provides supplement information to the JC-VSD Series II Installation Manual LIT-12011772 specific to the JC-VSD FP Series II IntelliPass® and IntelliDisconnect® products. These products are offered with input/output voltages of 208, 230, and 480 Vac with hp ranges from 1 to 125 hp. Both UL Type 1 and Type 3R enclosures are available.

For drive setup and operation, i.e., application, keypad use, drive and motor parameters setup, see the Quick Start Guide LIT-12011775 included with the drive. The drive Startup Wizard can be used to complete the process. For more information on speed control and other JC-VSD Series II drive features, see JC-VSD Series II Application Manual LIT-12011771. The Application Manual and can be found at <http://www.johnsoncontrols.com>

Catalog/style numbering

Figure 1. JC-VSD FP Series II master product part number matrix—IntelliPass/IntelliDisconnect

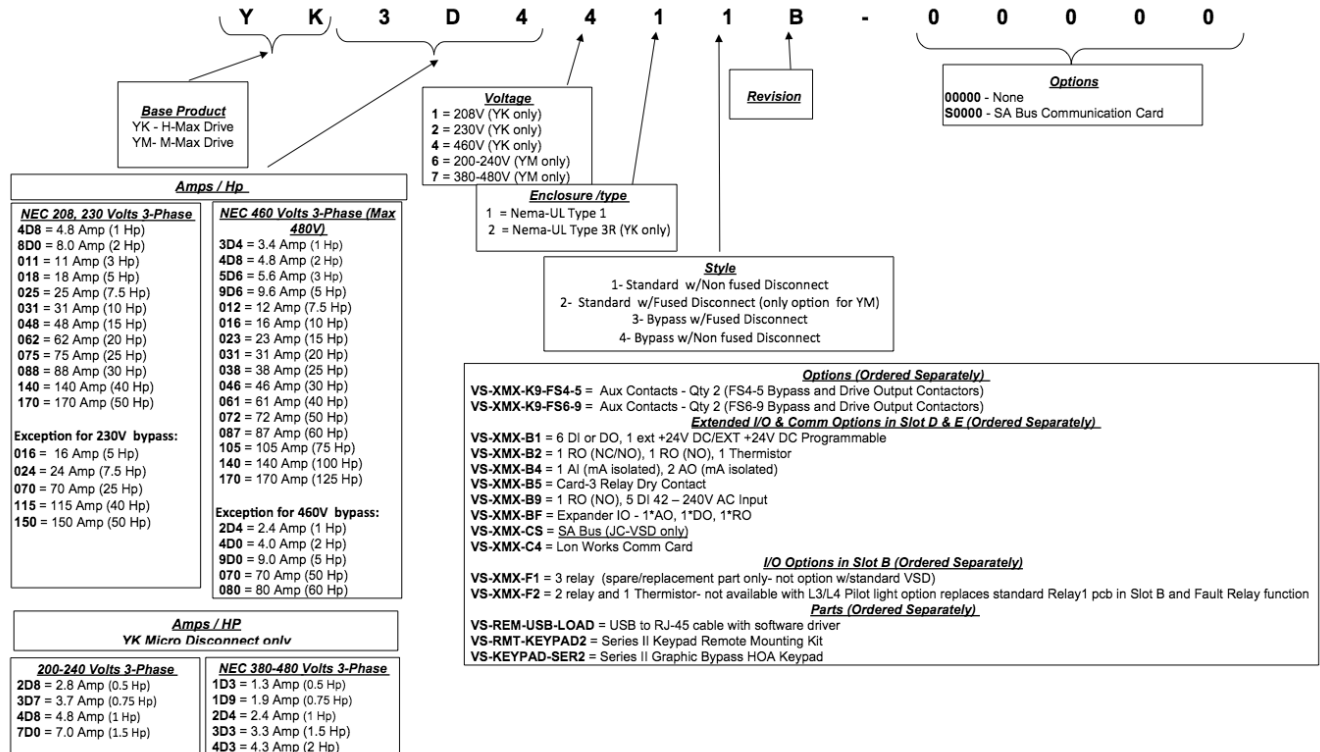

Identification

Figure 2. JC-VSD FP Series II IntelliPass/IntelliDisconnect carton label

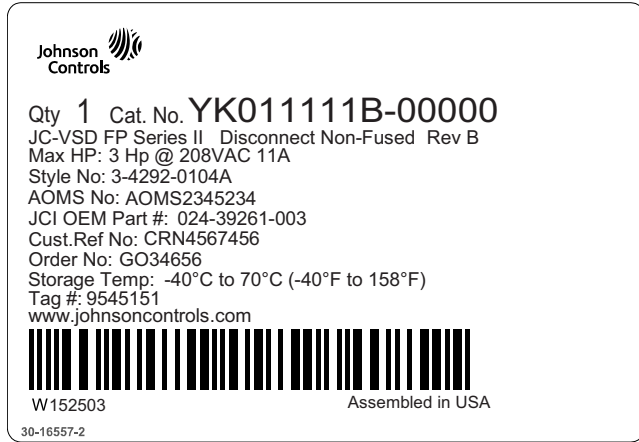
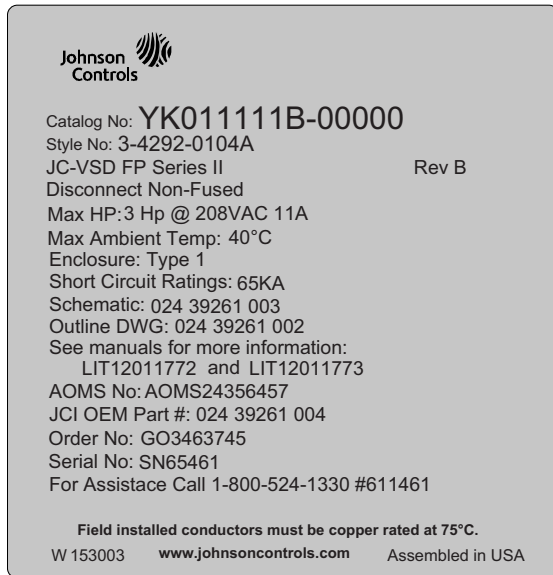

Figure 3. JC-VSD FP Series II IntelliPass/IntelliDisconnect nameplate



Component diagrams

IntelliPass and IntelliDisconnect—typical component locations

Figure 4. Type 1 IntelliDisconnect

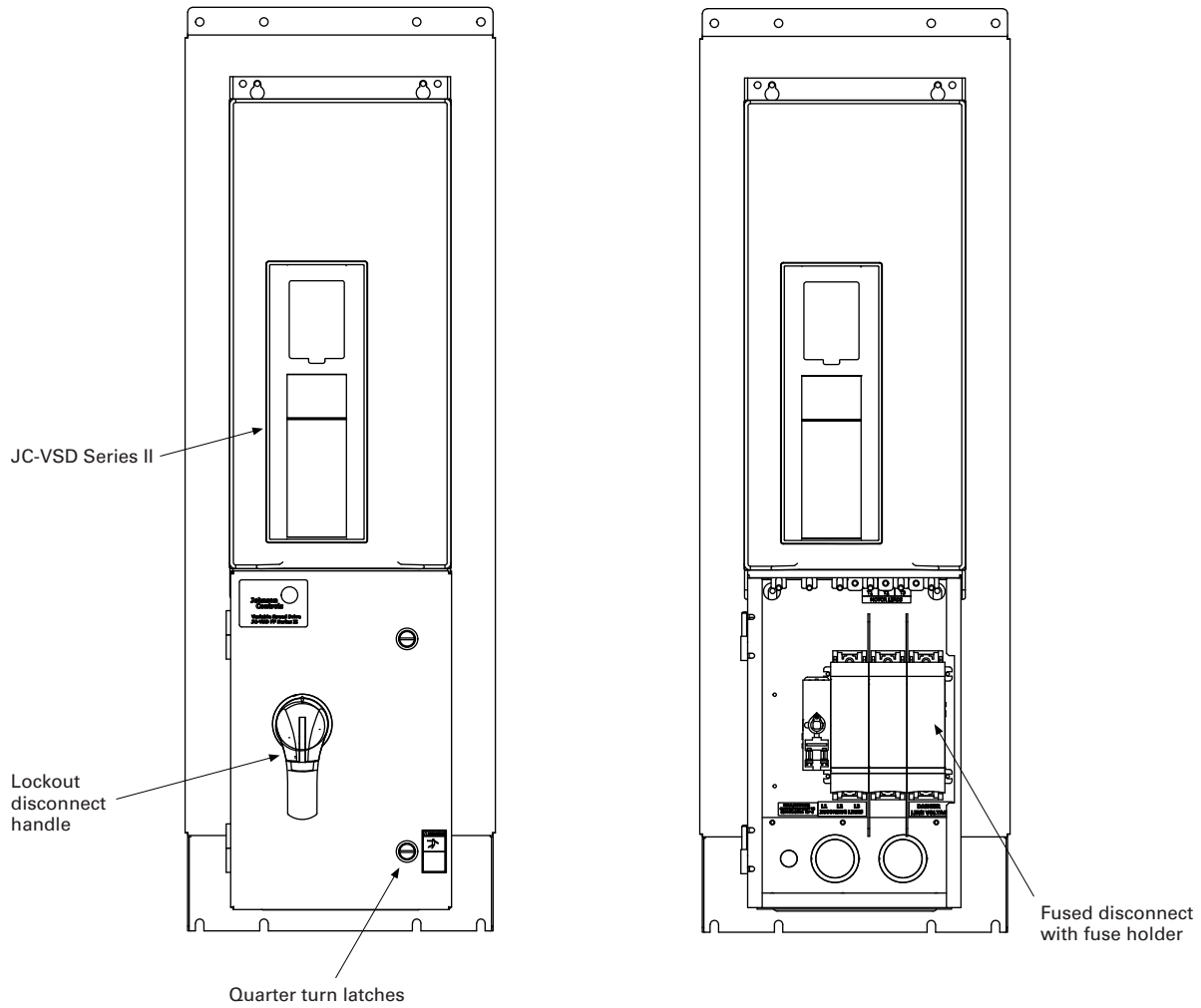

Figure 5. Type 1 IntelliPass

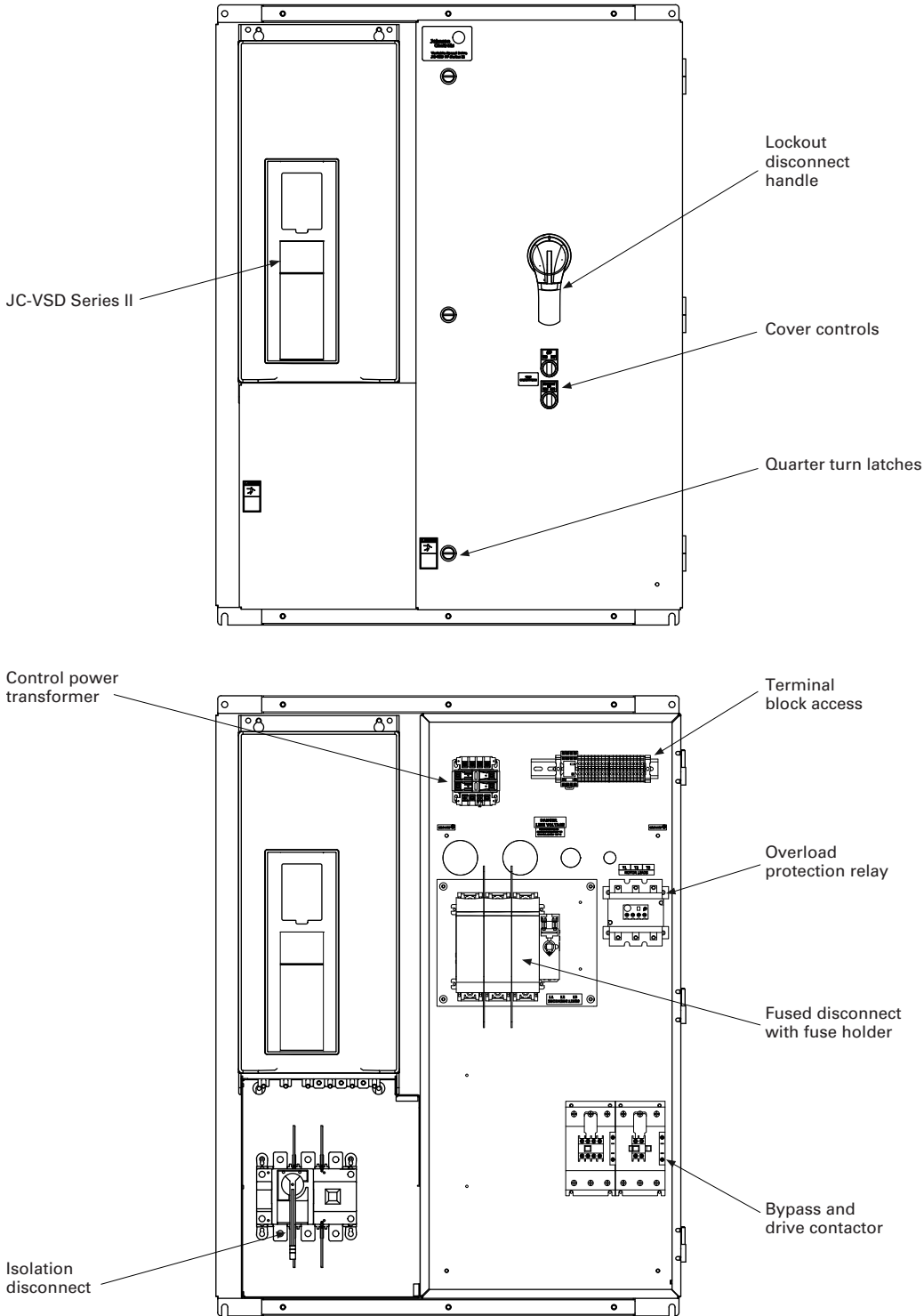

Figure 6. Type 3R IntelliDisconnect

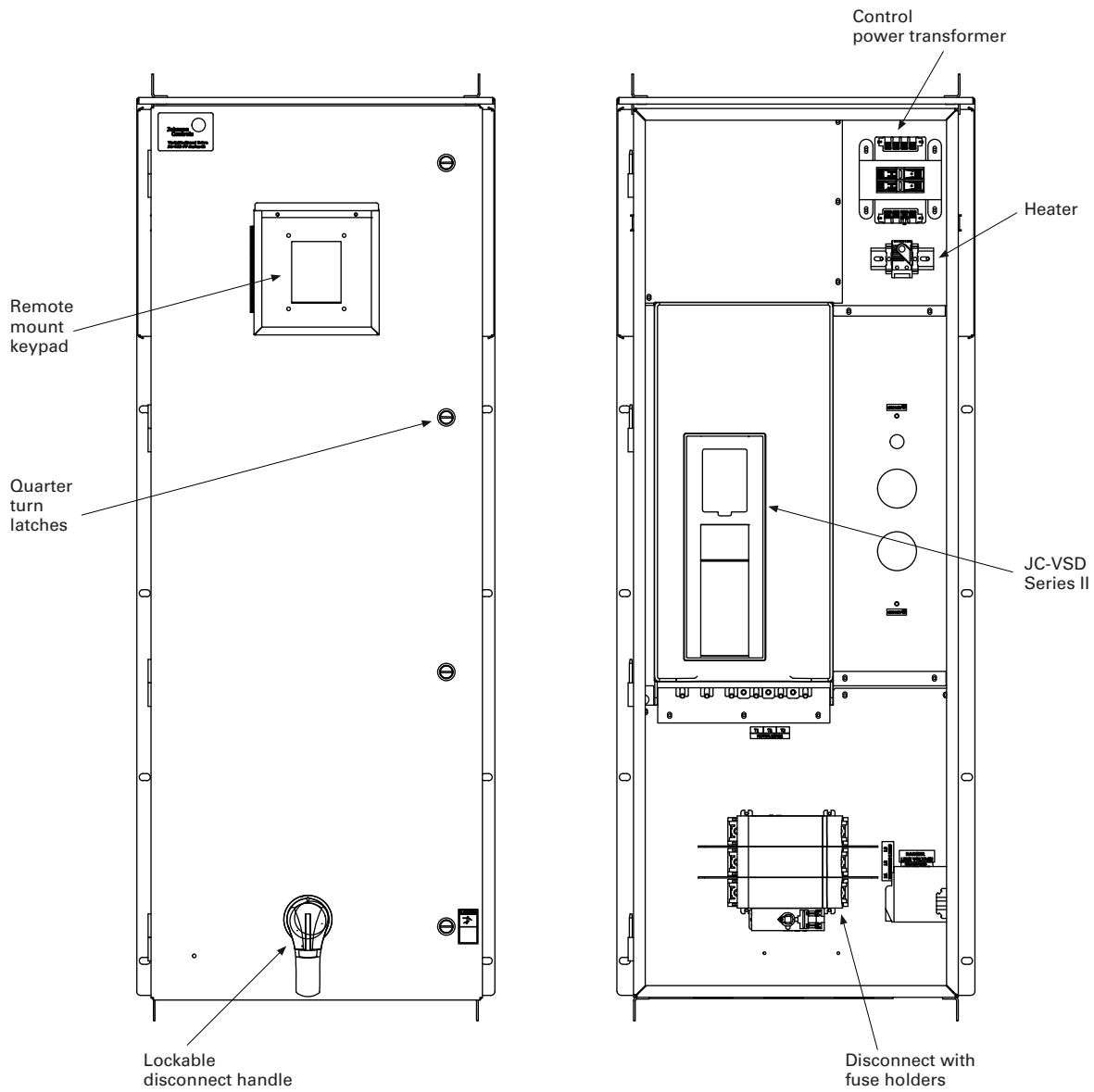

Figure 7. Type 3R IntelliPass

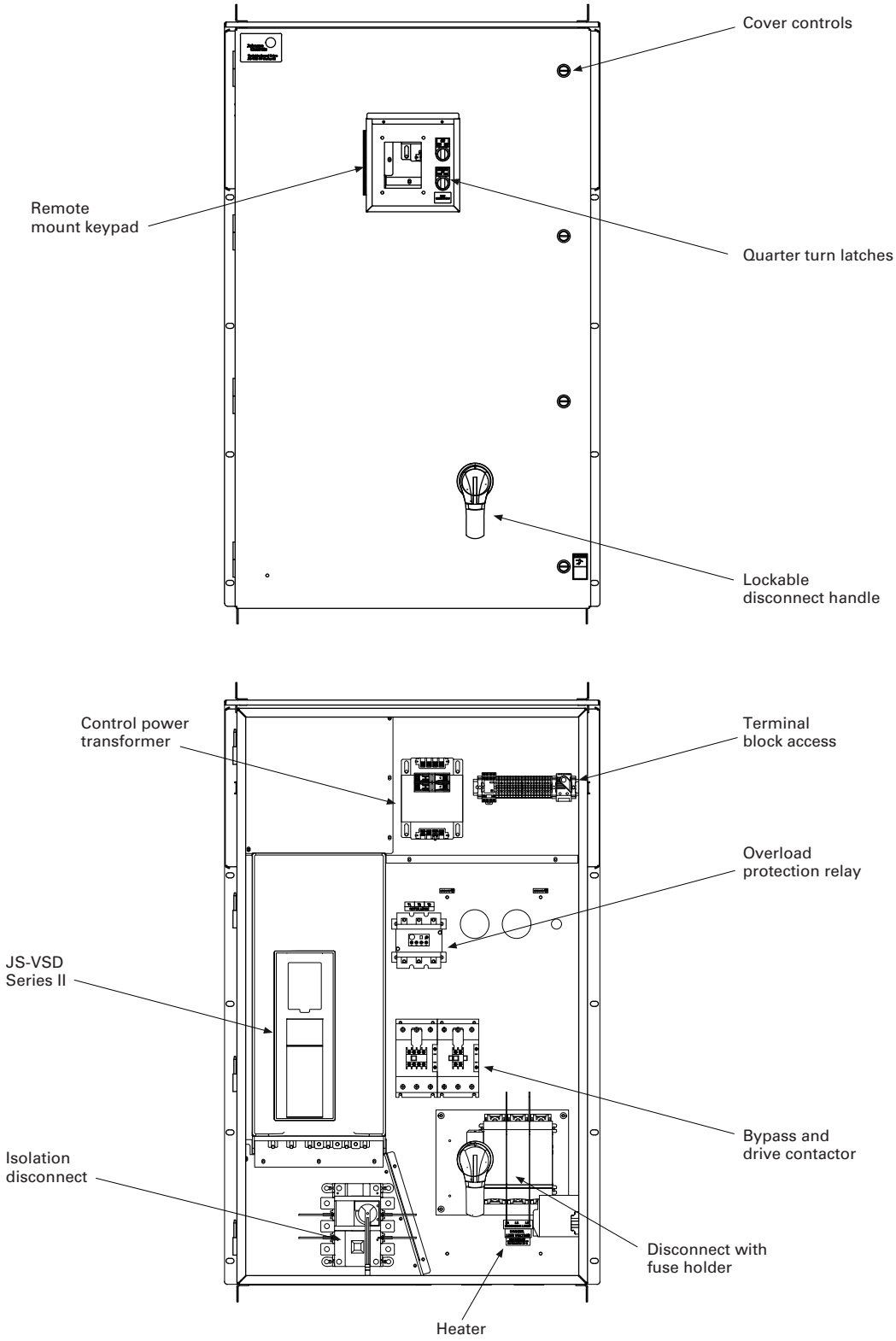
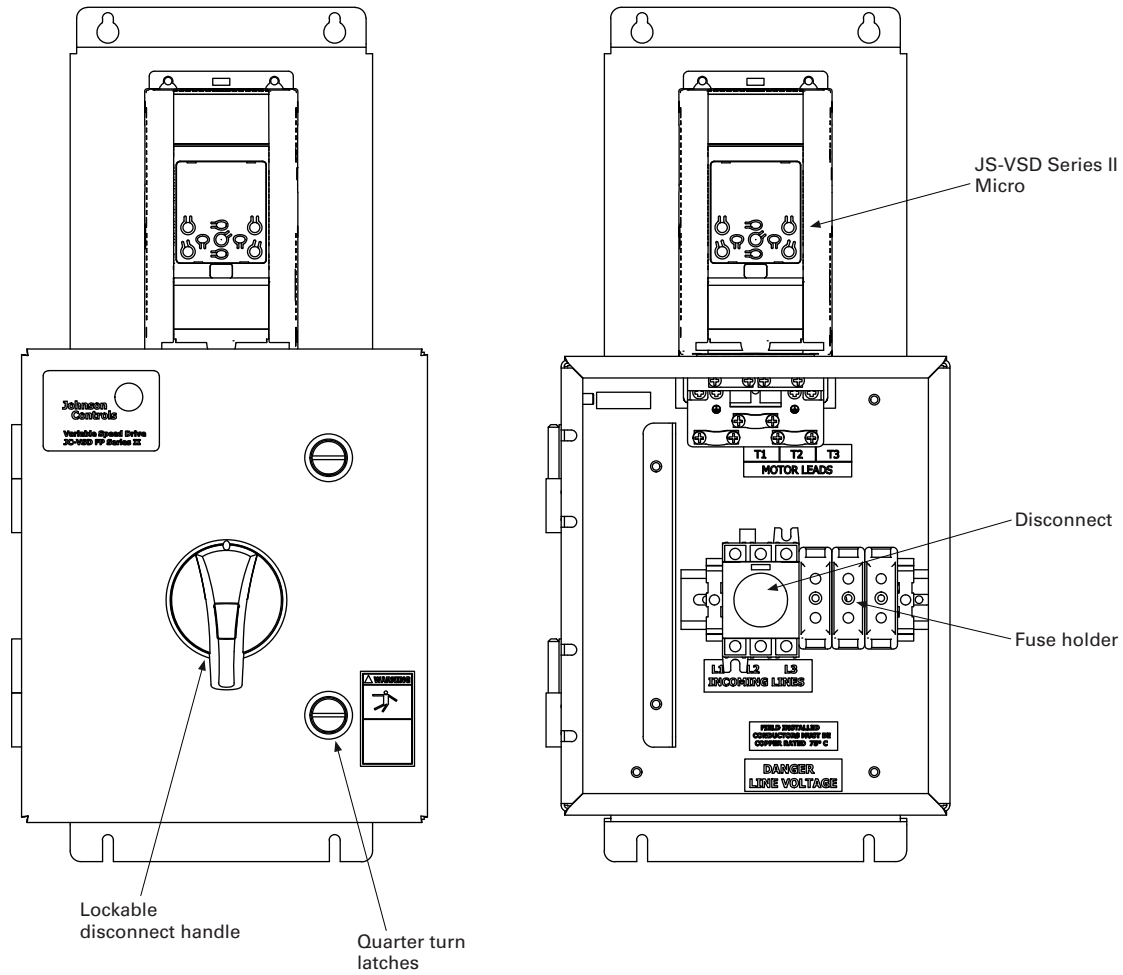

Figure 8. Type 1 Micro Disconnect



Standard factory wired components

The IntelliPass and IntelliDisconnect have the following factory installed options. Any additional options are sold separately. See part numbering matrix for ordering information.

Drive isolation fuses

This option is available for both the IntelliPass and IntelliDisconnect Fused Disconnect designs 208/230 V up to 50 hp and 480 V models up to 125 hp.

Three power fuses are supplied wired to the drive input. They are provided between the disconnect device and drive. The fuses are not used in the bypass mode. The fuses are for drive protection only. They are listed in the following table and the Type J are sized according. See IntelliDisconnect or Typical IntelliPass schematic.

Table 1. hp rating and fuse rating (A)

hp	208 V fuse	230 V fuse	460 V fuse
1	10	10	6
2	20	20	10
3	25	25	10
5	30	30	20
7.5	60	60	25
10	60	60	30
15	60	100	30
20	100	100	60
25	100	100	60
30	200	200	60
40	200	200	125
50	200	200	150
60	N/A	N/A	175
75	N/A	N/A	200
100	N/A	N/A	200
125	N/A	N/A	200

Figure 9. Fused disconnect



Manual bypass switch

This option is available on the IntelliPass models only. This option includes a 3-position door mounted selector switch—marked VFD / OFF / BYP. This switch manually overrides the bypass control from the system (keypad) and puts unit in bypass. See typical IntelliPass schematic.

When the door switch is in the drive position, the JC-VSD Series II Drive logic controls the motor and the keypad selects the operation (drive or bypass), the control source and place (HOA, KEYPAD, or Terminal block).

When the door switch is moved to bypass, the drive output contactor will be forced open and the bypass contactor will be forced closed. The motor will immediately start and run full speed across the line regardless of the state of the system or drive. The keypad display will show “Bypass”. When the switch is moved back to the drive position, drive operation is restored after a system restart.

Figure 10. Door 3-position switches



Figure 11. Larger framed bypass contactor

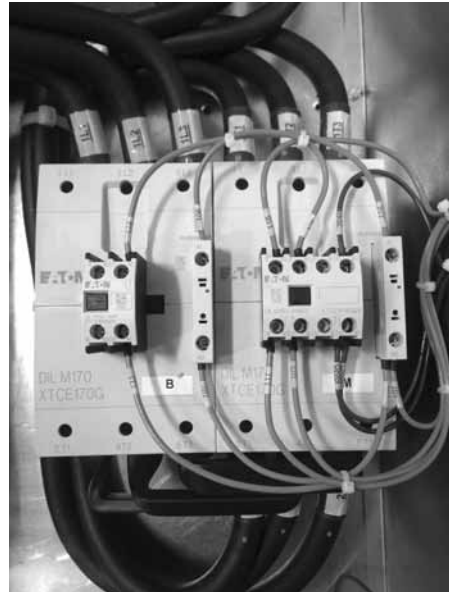
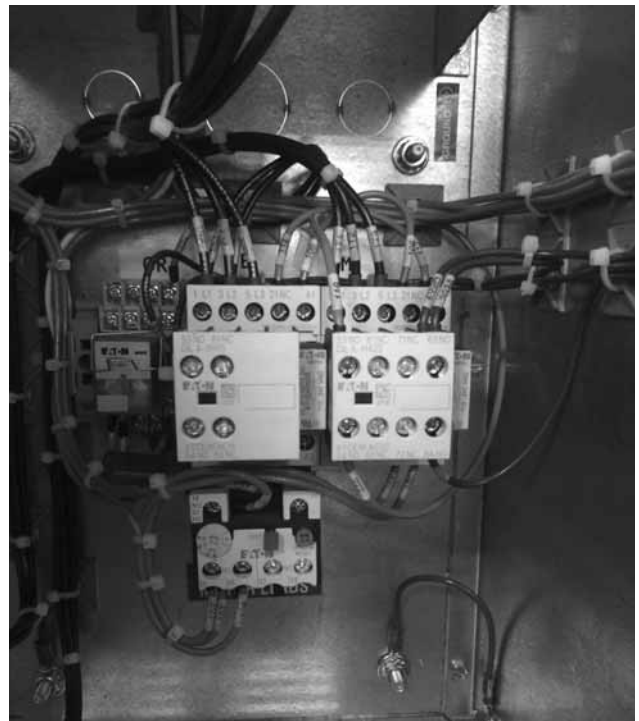

Figure 12. Lower framed bypass contactor



Space heater

Type 3R enclosures only

This option aids in preventing or reducing condensation from forming in the enclosure when the drive is inactive. See selection table below for the size of heater that is installed in each enclosure size. A control transformer and fusing is also provided to power the heater. See schematics for more information. The heater includes a user adjustable thermostat for variable temperature control and an internal fan.

Table 2. Space heater

Type 3R IntelliDisconnect enclosure size	Heater size (W) 120 V rated	Type 3R IntelliPass enclosure size	Heater size (W) 120 V rated
C1	150	D1	150
C2	150	D2	150
C3	150	D3	150
C4	150	D4	250
C5	250	D5	250
C6	250	D6	250

Setting the thermostat

The heater is controlled by an adjustable thermostat. Set the thermostat to the desired temperature. It is recommended not to exceed 75 °F for most applications. The heater is active at all times when the main disconnect is closed including when in the Drive, Off, or Bypass operation. However, depending on the setting of the thermostat, the internal heat generated by the system when in operation should be enough to turn off the heater. Generally the heater requires no maintenance because the fan bearings are permanently lubricated and sealed.

Plug-in options

Auxiliary contacts (bypass only)

The bypass and drive contactor come installed with auxiliary contacts. The configuration is used for bypass operation. There are open NO and NC contacts on each the bypass and drive contactor that can be used for customer use. See table below for open contact configuration based on voltage and horsepower.

Table 3. Auxiliary contacts (bypass only)

Voltage	hp rating	Contactor frame	Bypass contactor (B)		Drive contactor (M)	
			Number of NC available	Number of NO available	Number of NC available	Number of NO available
208 / 203 V	1–4	B	1	1	N/A	1 NO is wired to terminal block access 23 / 24
	5–10	C	1	1		
	15–20	D	N/A	1		
	25–30	F	N/A	1		
	40–50	G	N/A	1		
480 V	1–7.5	B	1	1		
	10–20	C	1	1		
	25–40	D	N/A	1		
	50–60	F	N/A	1		
	75–125	G	N/A	1		

Standard factory wired components

Option PCB cards

A number of plug-in cards are available to expand I/O and communications. The SA Bus communication card is the only factory installed option. Reference the catalog matrix for ordering. All other cards are sold separately.

Figure 13. Option PCB cards

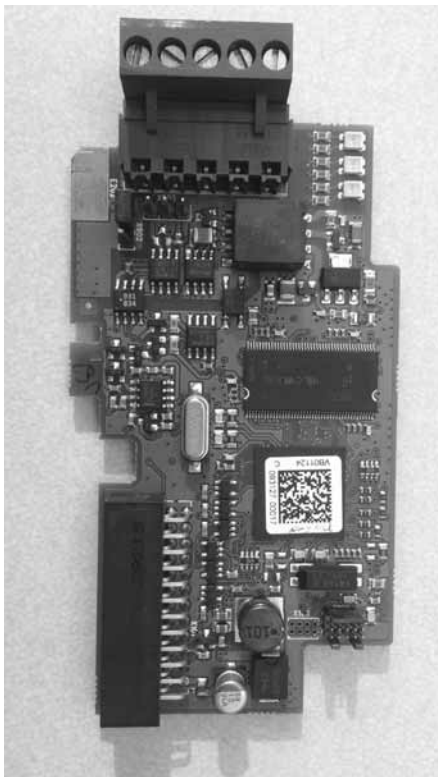

High temperature option

For NEMA Type 3R enclosures, vent covers are shipped loose inside the enclosure. These vent covers would need to be installed when the high temperature option is utilized. The vent cover would be installed on the outside bottom of the enclosure to cover the vents.

Also see JC-VSD Series II Installation Manual LIT-12011772 for more information on control wiring, control board layout and option PCBs.

Table 4. Option PCB cards

Part number	Description
VS-XXM-B1	I/O Expander Card, 6 DI/DO, Slot D/E VS-XXM-B1
VS-XXM-B2	I/O Expander Card 2 x RO + Thermistor, Slot D/E VS-XXM-B2
VS-XXM-B4	I/O Expander Card 1 x AI, 2 x AO (isolated), Slot D/E VS-XXM-B4
VS-XXM-B5	I/O Expander Card 3 x RO, Slot D/E VS-XXM-B5
VS-XXM-B9	I/O Expander Card 1 x RO, 5 x DI (42-240VAC), Slot D/E VS-XXM-B9
VS-XXM-BF	I/O expander Card, 1 x AO, 1 x DO, 1 x RO, Slot D/E VS-XXM-BF
VS-XXM-C4	Ionworks®, Slot D/E VS-XXM-C4
VS-XXM-CS	SA Bus, slot D/E

Dimensions and mounting

The IntelliPass / IntelliDisconnect physical dimensions are based on the enclosure frame size. See following table to determine the enclosure frame size based on horsepower and voltage.

- Weights and lifting provisions are on the dimension section and with the drawing provided with the unit
- Attach “load-rated” hooks or shackles to lifting eyes on back panel
- Always maintain a maximum of 45 degrees between the lifting cables and the vertical plane
- Do not pass ropes or cables through the lifting eyes as sharp edges may cause excessive wear and possible failure
- Select or adjust rigging lengths to compensate for unequal weight distribution of the load to keep unit in the upright position

The hardware to mount the Intellipass / IntelliDisconnect units, all frame sizes, is as follows:

- 3/8-16 Grade 5 Hex Head Bolt, with 3/8 lock washer and 3/8 flat washer. QTY 4 of each required. Torque to 20 lb-ft

Use the tables below to determine enclosure size and frame size based on voltage and horsepower. Enclosure dimensions differ between Type 1 IntelliDisconnect, Type 1 IntelliPass, Type 3R IntelliDisconnect, Type 3R IntelliPass, Type 1 Micro Disconnect.

Table 5. Enclosure size and frame size based on voltage and horsepower (208/230 V)

hp	Base drive	Type 1 disconnect	Type 1 bypass	Type 3R disconnect	Type 3R bypass
1	FS4	A1-4	B1-4	C1-4	D1-4
2	FS4	A1-4	B1-4	C1-4	D1-4
3	FS4	A1-4	B1-4	C1-4	D1-4
5	FS5	A1-5	B1-5	C1-5	D1-5
7.5	FS5	A2-5	B2-5	C2-5	D2-5
10	FS5	A2-5	B2-5	C2-5	D2-5
15	FS6	A3-6	B3-6	C3-6	D3-6
20	FS6	A3-6	B3-6	C3-6	D3-6
25	FS7	A4-7	B4-7	C4-7	D4-7
30	FS7	A4-7	B4-7	C4-7	D4-7
40	FS7	A4-8	B4-8	C4-8	D4-8
50	FS8	A6-8	B6-8	C6-8	D6-8
60	FS8	—	—	—	—
75	FS8	—	—	—	—

Dimensions and mounting

Table 6. Enclosure size and frame size based on voltage and horsepower (480 V)

hp	Base drive	Type 1 disconnect	Type 1 bypass	Type 3R disconnect	Type 3R bypass
1	FS4	A1-4	B1-4	C1-4	D1-4
2	FS4	A1-4	B1-4	C1-4	D1-4
3	FS4	A1-4	B1-4	C1-4	D1-4
5	FS4	A1-4	B1-4	C1-4	D1-4
7.5	FS4	A1-4	B1-4	C1-4	D1-4
10	FS5	A2-5	B2-5	C2-5	D2-5
15	FS5	A2-5	B2-5	C2-5	D2-5
20	FS5	A3-5	B3-5	C3-5	D3-5
25	FS6	A3-6	B3-6	C3-6	D3-6
30	FS6	A3-6	B3-6	C3-6	D3-6
40	FS6	A4-6	B4-6	C4-6	D4-6
50	FS7	A4-7	B4-7	C4-7	D4-7
60	FS7	A4-7	B4-7	C4-7	D4-7
75	FS7	A4-7	B4-7	C4-7	D4-7
100	FS8	A5-8	B5-8	C5-8	D5-8
125	FS8	A6-8	B6-8	C6-8	D6-8

Table 7. Type 1 Micro Disconnect

hp	208/230 V	480 V
0.5	M1-1	M1-1
0.75	M1-2	M1-1
1	M1-2	M1-1
1.5	M1-2	M1-2
2	—	M1-2

Figure 14. Type 1 IntelliDisconnect dimensions

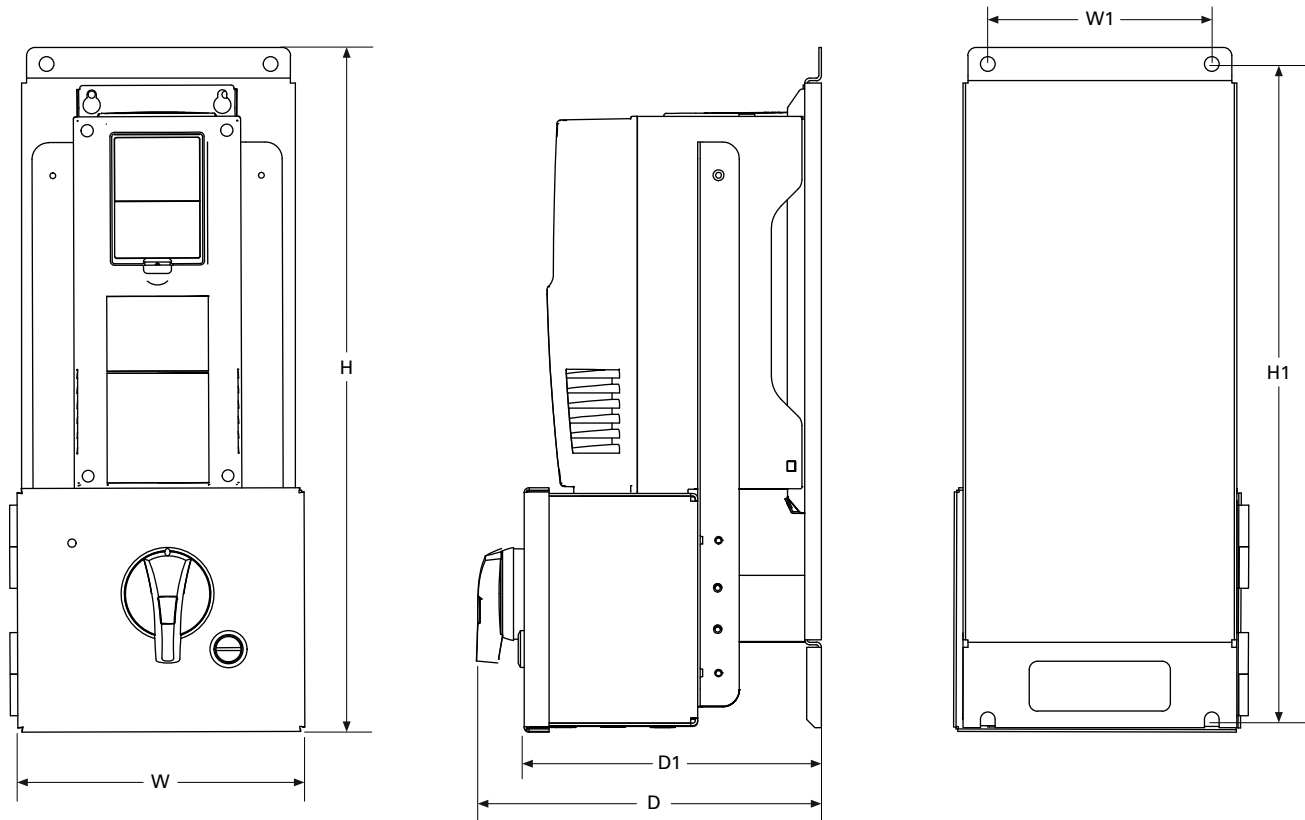

Table 8. Type 1 IntelliDisconnect dimensions

Approximate dimensions in inches (mm)

Enclosure size— drive frame size	H	H1	W	W1	D	D1	Weight in lb (kg)
A1-4	20.61 (523.5)	19.75 (501.7)	8.65 (219.7)	6.75 (171.5)	10.40 (264.2)	8.96 (227.6)	34 (15)
A1-5	30.00 (762.0)	29.00 (736.6)	8.65 (219.7)	6.75 (171.5)	11.18 (284.0)	9.74 (247.4)	54 (25)
A2-5	30.00 (762.0)	29.00 (736.6)	8.65 (219.7)	6.75 (171.5)	11.18 (284.0)	9.74 (247.4)	54 (25)
A3-5	20.61 (523.5)	19.75 (501.7)	8.65 (219.7)	6.75 (171.5)	10.40 (264.2)	8.96 (227.6)	54 (25)
A3-6	32.50 (825.5)	31.50 (800.1)	10.40 (264.2)	7.50 (190.5)	11.41 (289.8)	9.97 (253.2)	101 (46)
A4-6	41.03 (1042.2)	39.50 (1003.3)	12.40 (315.0)	10.50 (266.7)	13.67 (347.2)	11.97 (304.0)	113 (51)
A4-7	41.55 (1055.4)	39.50 (1003.3)	12.40 (315.0)	10.50 (266.7)	13.94 (354.1)	12.25 (311.2)	200 (91)
A4-8	44.04 (1118.6)	39.50 (1003.3)	12.00 (304.8)	10.50 (266.7)	15.86 (402.8)	14.17 (359.9)	363 (165)
A5-8	44.05 (1118.9)	42.06 (1068.3)	12.00 (304.8)	10.50 (266.7)	15.86 (402.8)	14.17 (359.9)	363 (165)
A6-8	47.65 (1210.3)	46.50 (1181.1)	16.00 (406.4)	14.50 (368.3)	15.86 (402.8)	14.17 (359.9)	363 (165)

Figure 15. Type 1 IntelliDisconnect knockout dimensions

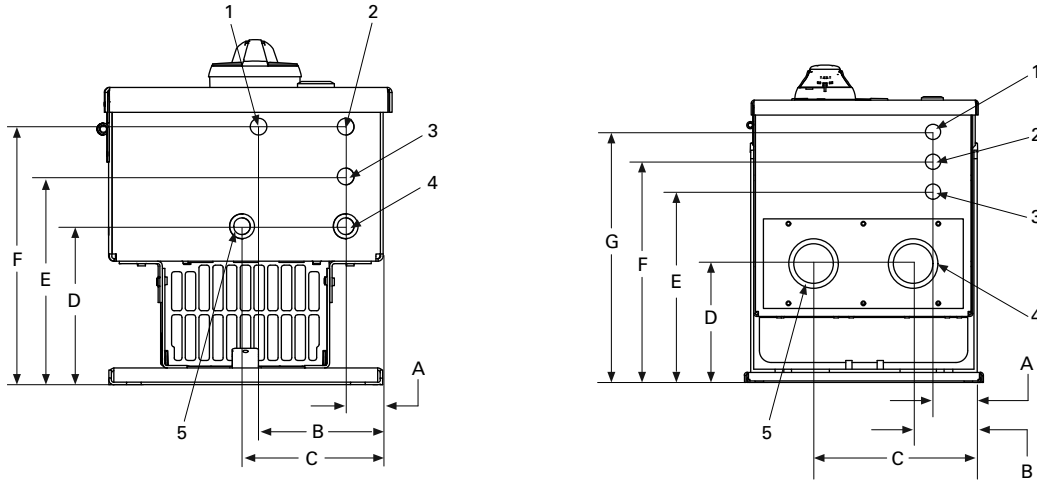

Table 9. Type 1 IntelliDisconnect knockout dimensions

Approximate dimensions in inches (mm)

Enclosure size	A	B	C	D	E	F	G	Conduit 1, 2 & 3	Conduit 4 & 5
A1-4	1.12 (28.4)	3.74 (95.0)	4.24 (107.7)	4.77 (121.2)	6.27 (159.3)	7.77 (197.4)		0.875	1.109 & 0.875
A1-5	1.12 (28.4)	3.74 (95.0)	4.24 (107.7)	5.55 (141.0)	7.05 (179.1)	8.55 (217.2)		0.875	1.109 & 0.875
A2-5	1.12 (28.4)	3.74 (95.0)	4.24 (107.7)	5.55 (141.0)	7.05 (179.1)	8.55 (217.2)		0.875	1.109 & 0.875
A3-5	1.12 (28.4)	3.74 (95.0)	4.24 (107.7)	4.77 (121.2)	6.27 (159.3)	7.77 (197.4)		0.875	1.375 & 1.109
A3-6	1.00 (25.4)	3.63 (92.2)	5.03 (127.8)	5.79 (147.1)	7.29 (185.2)	8.79 (223.3)		0.875	1.375 & 1.109
A4-6	1.55 (39.4)	1.55 (39.4)	7.67 (194.8)	5.99 (152.1)	7.74 (196.6)	9.24 (234.7)	10.74 (272.8)	0.875	1.735 & 1.375
A4-7	1.55 (39.4)	1.55 (39.4)	7.67 (194.8)	6.27 (159.3)	8.02 (203.7)	9.52 (241.8)	11.02 (280.0)	0.875	1.735 & 1.375
A4-8	2.47 (62.7)	3.47 (88.1)	8.47 (215.1)	5.96 (151.4)	9.58 (243.3)	11.08 (281.4)	12.58 (319.5)	0.875	1.735 & 1.375
A5-8	2.53 (64.3)	3.53 (89.7)	8.53 (216.7)	5.96 (151.4)	9.58 (243.3)	11.08 (281.4)	12.58 (319.5)	0.875	1.984 & 1.734
A6-8	4.53 (115.1)	5.53 (140.5)	10.53 (267.5)	5.96 (151.4)	9.58 (243.3)	11.08 (281.4)	12.58 (319.5)	0.875	1.984 & 1.734

Figure 16. Type 1 IntelliPass dimensions

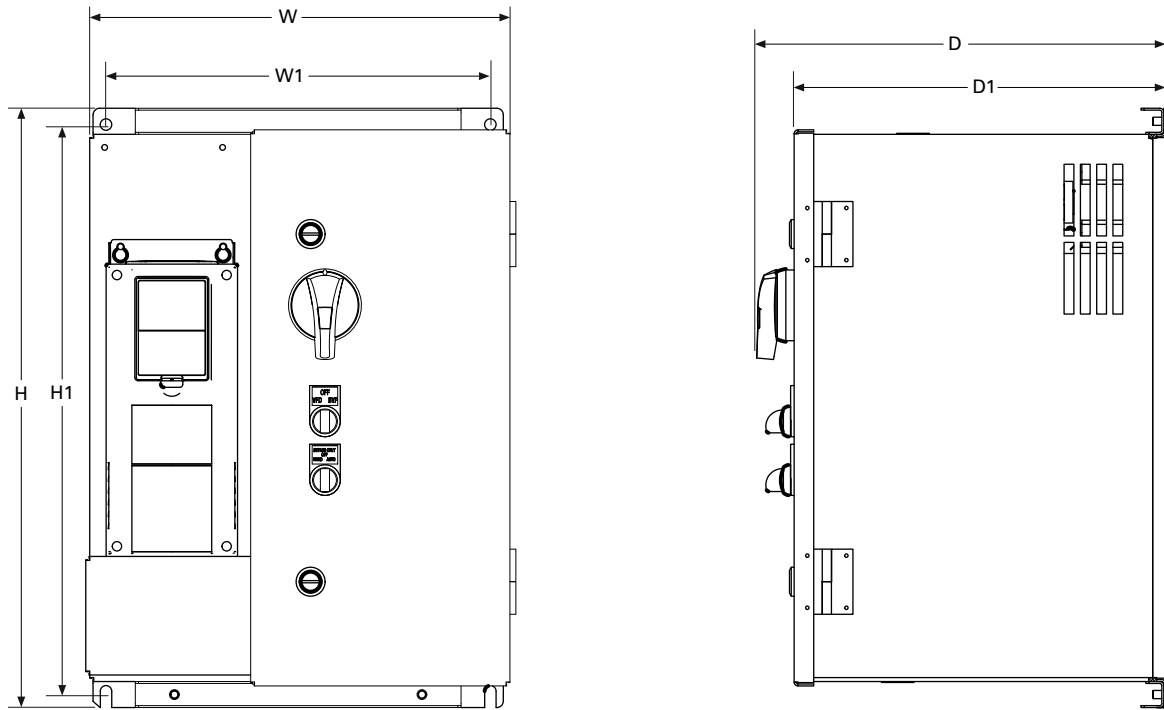

Table 10. Type 1 IntelliPass dimensions

Approximate dimensions in inches (mm)

Enclosure size— drive frame size	H	H1	W	W1	D	D1	Weight in lb (kg)
B1-4	23.00 (584.2)	21.75 (552.5)	16.28 (413.5)	14.75 (374.7)	15.70 (398.8)	14.26 (362.2)	64 (29)
B1-5	23.00 (584.2)	21.75 (552.5)	16.28 (413.5)	14.75 (374.7)	15.70 (398.8)	14.26 (362.2)	88 (40)
B2-5	30.00 (762.0)	29.00 (736.6)	16.28 (413.5)	14.75 (374.7)	15.70 (398.8)	14.26 (362.2)	88 (40)
B3-5	31.50 (800.1)	30.50 (774.7)	19.13 (485.9)	17.75 (450.9)	15.70 (398.8)	14.26 (362.2)	88 (40)
B3-6	31.50 (800.1)	30.50 (774.7)	19.13 (485.9)	17.75 (450.9)	15.70 (398.8)	14.26 (362.2)	145 (66)
B4-6	39.50 (1003.3)	38.25 (971.6)	30.13 (765.3)	28.75 (730.3)	17.42 (442.5)	15.73 (399.5)	158 (72)
B4-7	42.75 (1085.9)	38.25 (971.6)	30.13 (765.3)	28.75 (730.3)	17.42 (442.5)	15.73 (399.5)	262 (119)
B4-8	42.90 (1089.7)	38.25 (971.6)	30.13 (765.3)	28.75 (730.3)	17.42 (442.5)	15.73 (399.5)	455 (207)
B5-8	44.00 (1117.6)	42.75 (1085.9)	33.13 (841.5)	31.75 (806.5)	17.42 (442.5)	15.73 (399.5)	455 (207)
B6-8	44.00 (1117.6)	42.75 (1085.9)	33.13 (841.5)	31.75 (806.5)	17.42 (442.5)	15.73 (399.5)	455 (207)

Figure 17. Type 1 IntelliPass knockout dimensions

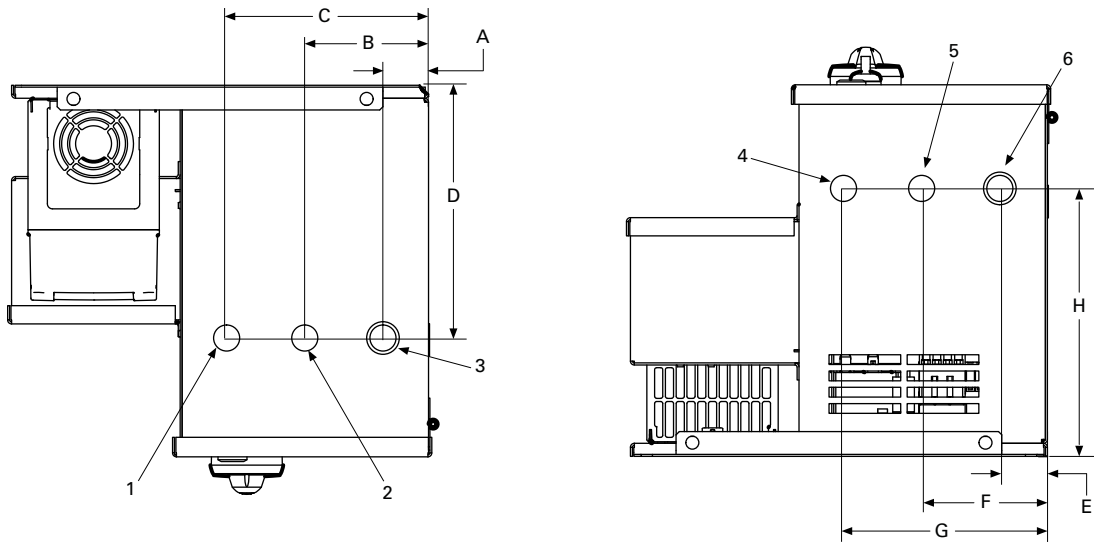

Table 11. Type 1 IntelliPass knockout dimensions

Approximate dimensions in inches (mm)

Enclosure size— drive frame size	A	B	C	D	Conduit 1	Conduit 2	Conduit 3
B1-4	1.75 (44.5)	4.75 (120.7)	7.75 (196.9)	9.70 (246.4)	1.109	1.109	1.375 & 1.109
B1-5	1.75 (44.5)	4.75 (120.7)	7.75 (196.9)	9.70 (246.4)	1.109	1.109	1.375 & 1.109
B2-5	1.75 (44.5)	4.75 (120.7)	7.75 (196.9)	9.78 (248.4)	1.109	1.109	1.375 & 1.109
B3-5	2.13 (54.1)	5.13 (130.3)	8.13 (206.5)	9.78 (248.4)	1.109	1.109	1.984 & 1.109
B3-6	2.13 (54.1)	5.13 (130.3)	8.13 (206.5)	9.78 (248.4)	1.109	1.109	1.984 & 1.109
B4-6	6.15 (156.2)	10.15 (257.8)	14.00 (255.6)	10.26 (260.6)	1.109	1.109	1.964 & 1.109
B4-7	6.15 (156.2)	10.15 (257.8)	14.00 (255.6)	10.26 (260.6)	1.109	1.109	1.964 & 1.109
B4-8	6.15 (156.2)	10.15 (257.8)	14.00 (255.6)	10.26 (260.6)	1.109	1.109	1.964 & 1.109
B5-8	6.09 (154.7)	11.09 (281.7)	16.09 (408.7)	10.11 (256.8)	1.375	2.469 & 1.984	2.469 & 1.984
B6-8	6.09 (154.7)	11.09 (281.7)	16.09 (408.7)	10.11 (256.8)	1.375	2.469 & 1.984	2.469 & 1.984

Enclosure size— drive frame size	E	F	G	H	Conduit 4	Conduit 5	Conduit 6
B1-4	1.83 (46.5)	4.83 (122.7)	7.83 (198.9)	10.26 (260.6)	1.109	1.109	1.375 & 1.109
B1-5	1.83 (46.5)	4.83 (122.7)	7.83 (198.9)	10.26 (260.6)	1.109	1.109	1.375 & 1.109
B2-5	1.75 (44.5)	4.75 (120.7)	7.75 (196.9)	9.78 (248.4)	1.109	1.109	1.375 & 1.109
B3-5	2.13 (54.1)	5.13 (130.3)	8.13 (206.5)	9.78 (248.4)	1.109	1.109	1.984 & 1.109
B3-6	2.13 (54.1)	5.13 (130.3)	8.13 (206.5)	9.78 (248.4)	1.109	1.109	1.984 & 1.109
B4-6	6.09 (154.7)	10.08 (256.0)	14.00 (255.6)	10.11 (256.8)	1.109	1.109	1.964 & 1.109
B4-7	6.09 (154.7)	10.08 (256.0)	14.00 (255.6)	10.11 (256.8)	1.109	1.109	1.964 & 1.109
B4-8	6.09 (154.7)	10.08 (256.0)	14.00 (255.6)	10.11 (256.8)	1.109	1.109	1.964 & 1.109
B5-8	6.09 (154.7)	11.09 (281.7)	16.09 (408.7)	10.11 (256.8)	1.375	2.469 & 1.984	2.469 & 1.984
B6-8	6.09 (154.7)	11.09 (281.7)	16.09 (408.7)	10.11 (256.8)	1.375	2.469 & 1.984	2.469 & 1.984

Figure 18. Type 3R IntelliDisconnect dimensions

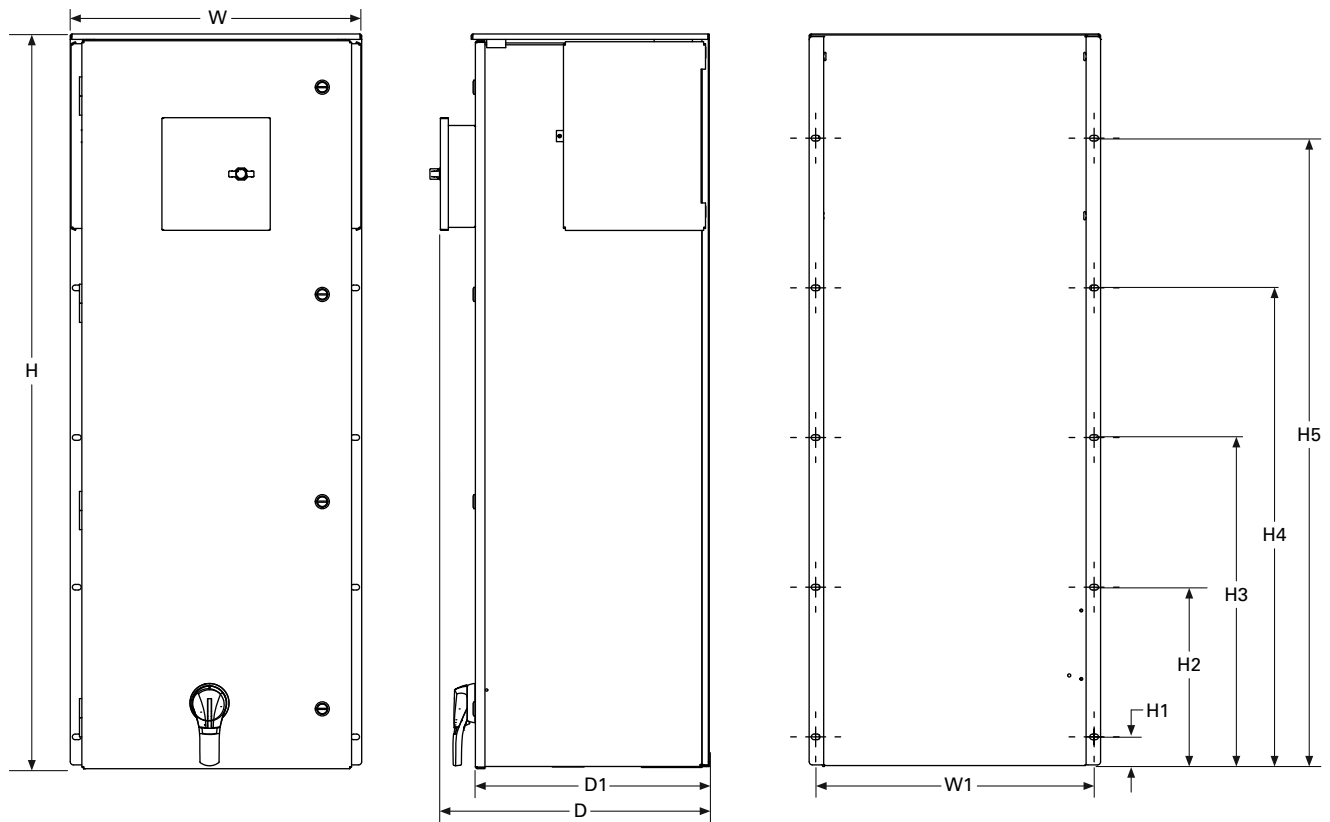

Table 12. Type 3R IntelliDisconnect dimensions

Approximate dimensions in inches (mm)

Enclosure size— drive frame size	H	H1	H2	H3	H4	H5	W	W1	D	D1	Weight in lb (kg)
C1-4	22.79 (578.9)	3.75 (95.25)	11.25 (285.8)	18.75 (476.25)	—	—	15.13 (384.3)	14.19 (360.4)	14.24 (361.7)	11.48 (291.6)	46 (21)
C1-5	22.79 (578.9)	3.75 (95.25)	11.25 (285.8)	18.75 (476.25)	—	—	15.13 (384.3)	14.19 (360.4)	14.24 (361.7)	11.48 (291.6)	63 (29)
C2-5	29.79 (756.7)	4.10 (104.1)	14.10 (358.1)	24.10 (612.1)	—	—	15.13 (384.3)	14.19 (360.4)	14.24 (361.7)	11.48 (291.6)	66 (30)
C3-5	31.72 (805.7)	0.70 (17.78)	9.87 (250.7)	19.03 (483.4)	28.20 (716.3)	—	18.13 (460.5)	17.19 (436.6)	14.24 (361.7)	11.48 (291.6)	66 (30)
C3-6	31.72 (805.7)	0.70 (17.78)	9.87 (250.7)	19.03 (483.4)	28.20 (716.3)	—	18.13 (460.5)	17.19 (436.6)	14.24 (361.7)	11.48 (291.6)	113 (51)
C4-6	53.67 (1363.2)	3.37 (85.6)	12.87 (326.9)	22.37 (568.2)	31.87 (809.5)	41.37 (1050.8)	17.63 (447.8)	16.61 (421.9)	16.11 (409.2)	13.36 (339.3)	128 (58)
C4-7	53.67 (1363.2)	3.37 (85.6)	12.87 (326.9)	22.37 (568.2)	31.87 (809.5)	41.37 (1050.8)	17.63 (447.8)	16.61 (421.9)	16.11 (409.2)	13.36 (339.3)	226 (103)
C4-8	53.67 (1363.2)	3.37 (85.6)	12.87 (326.9)	22.37 (568.2)	31.87 (809.5)	41.37 (1050.8)	17.63 (447.8)	16.61 (421.9)	18.11 (460.0)	15.36 (390.1)	378 (172)
C5-8	53.67 (1363.2)	1.87 (47.5)	11.87 (301.5)	21.87 (555.5)	31.87 (809.5)	41.37 (1050.8)	21.38 (543.1)	20.36 (517.1)	18.11 (460.0)	15.36 (390.1)	405 (184)
C6-8	53.67 (1363.2)	2.20 (55.9)	13.95 (354.3)	25.70 (652.8)	37.45 (951.2)	49.20 (1249.7)	22.88 (581.2)	21.86 (555.2)	21.11 (539.2)	18.36 (466.3)	405 (184)

Dimensions and mounting

Figure 19. Type 3R IntelliDisconnect knockout dimensions

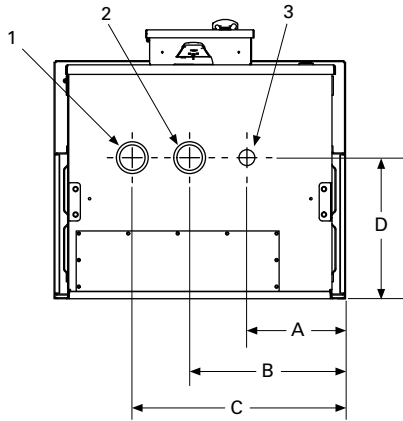

Table 13. Type 3R IntelliDisconnect knockout dimensions

Approximate dimensions in inches (mm)

Enclosure size— drive frame size	A	B	C	D	Conduit 1	Conduit 2	Conduit 3
C1-4	4.99 (126.7)	7.99 (202.9)	10.99 (279.1)	6.07 (154.2)	1.375 & 1.109	1.109	1.109
C1-5	4.99 (126.7)	7.99 (202.9)	10.99 (279.1)	6.07 (154.2)	1.375 & 1.109	1.109	1.109
C2-5	4.99 (126.7)	7.99 (202.9)	10.99 (279.1)	6.57 (166.9)	1.375 & 1.109	1.109	1.109
C3-5	7.99 (202.9)	10.99 (279.1)	13.99 (355.3)	6.57 (166.9)	1.109	1.109	1.734 & 1.109
C3-6	7.99 (202.9)	10.99 (279.1)	13.99 (355.3)	6.57 (166.9)	1.109	1.109	1.734 & 1.109
C4-6	6.49 (164.8)	9.49 (241.0)	12.49 (317.2)	7.58 (192.5)	1.984 & 1.109	1.109	1.109
C4-7	6.49 (164.8)	9.49 (241.0)	12.49 (317.2)	7.58 (192.5)	1.984 & 1.109	1.109	1.109
C4-8	6.49 (164.8)	9.49 (241.0)	12.49 (317.2)	7.58 (192.5)	1.984 & 1.109	1.109	1.109
C5-8	6.24 (158.5)	10.74 (272.8)	15.24 (387.1)	8.08 (205.2)	2.469 & 1.948	2.469 & 1.948	1.375
C6-8	7.74 (196.6)	12.24 (310.9)	16.74 (425.2)	11.08 (281.4)	2.469 & 1.984	2.469 & 1.984	1.375

Figure 20. Type 3R IntelliPass dimensions

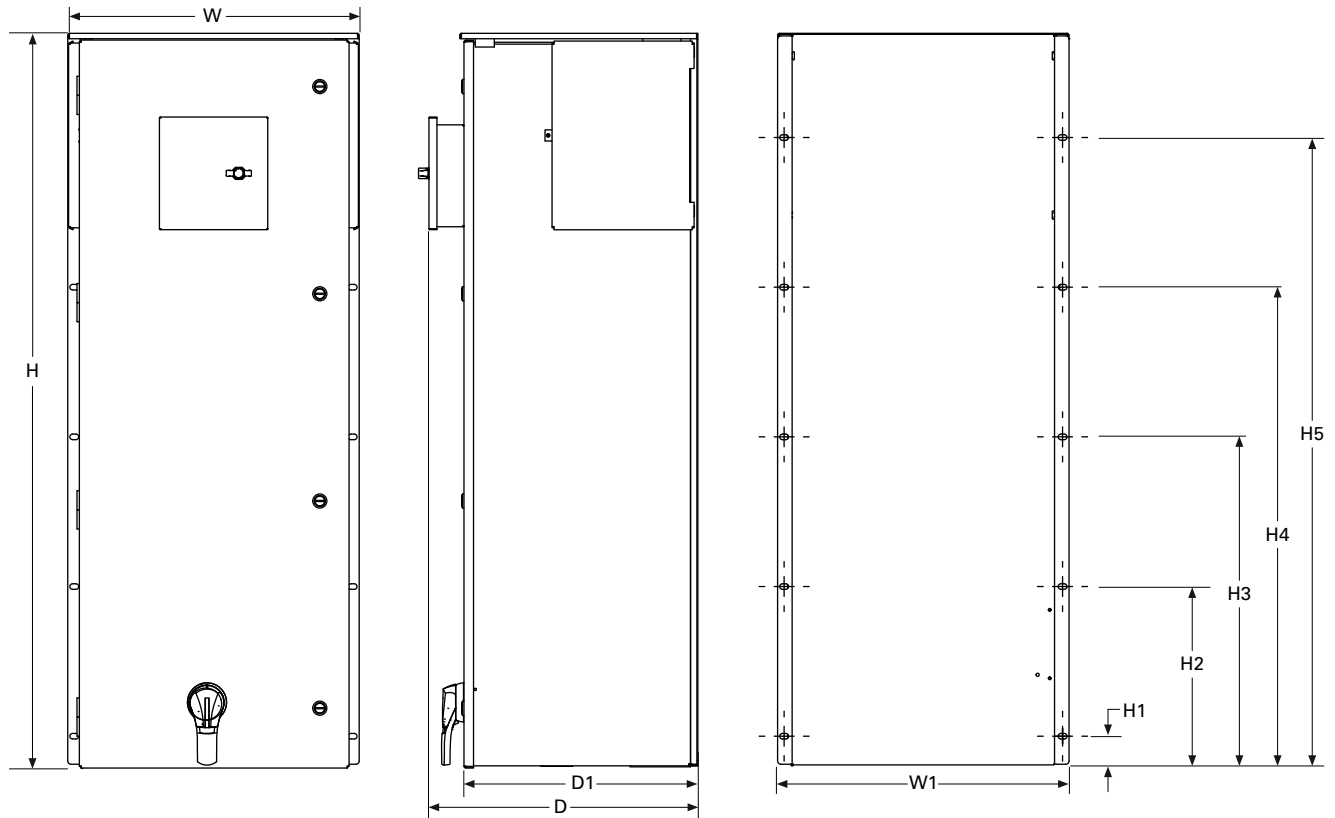

Table 14. Type 3R IntelliPass dimensions

Approximate dimensions in inches (mm)

Enclosure size— drive frame size	H	H1	H2	H3	H4	H5	W	W1	D	D1	Weight in lb (kg)
D1-4	22.87 (580.9)	1.25 (31.8)	8.75 (222.3)	16.25 (412.8)	—	—	18.13 (460.5)	17.19 (436.6)	17.23 (437.6)	14.48 (367.8)	80 (36)
D1-5	22.87 (580.9)	1.25 (31.8)	8.75 (222.3)	16.25 (412.8)	—	—	18.13 (460.5)	17.19 (436.6)	17.23 (437.6)	14.48 (367.8)	104 (47)
D2-5	22.87 (580.9)	1.00 (25.4)	8.50 (215.9)	16.00 (406.4)	—	—	18.13 (460.5)	17.19 (436.6)	17.23 (437.6)	14.48 (367.8)	104 (47)
D3-5	30.74 (780.8)	3.25 (82.6)	13.25 (336.6)	23.25 (590.6)	—	—	21.13 (536.7)	20.19 (512.8)	17.23 (437.6)	14.48 (367.8)	104 (47)
D3-6	30.74 (780.8)	3.25 (82.6)	13.25 (336.6)	23.25 (590.6)	—	—	21.13 (536.7)	20.19 (512.8)	17.23 (437.6)	14.48 (367.8)	164 (74)
D4-6	48.67 (1236.2)	1.75 (44.5)	10.25 (260.4)	18.75 (476.3)	27.25 (692.2)	35.75 (908.1)	28.13 (714.5)	27.11 (688.6)	18.11 (460.0)	15.36 (390.1)	183 (83)
D4-7	48.67 (1236.2)	1.75 (44.5)	10.25 (260.4)	18.75 (476.3)	27.25 (692.2)	35.75 (908.1)	28.13 (714.5)	27.11 (688.6)	18.11 (460.0)	15.36 (390.1)	291 (132)
D4-8	48.67 (1236.2)	1.75 (44.5)	10.25 (260.4)	18.75 (476.3)	27.25 (692.2)	35.75 (908.1)	28.13 (714.5)	27.11 (688.6)	18.11 (460.0)	15.36 (390.1)	485 (220)
D5-8	48.67 (1236.2)	2.00 (50.8)	11.50 (292.1)	21.00 (533.4)	30.50 (774.7)	40.00 (1016.0)	32.13 (816.1)	31.19 (792.2)	22.11 (561.6)	19.36 (491.7)	526 (239)
D6-8	50.17 (1274.3)	2.00 (50.8)	13.00 (330.2)	24.00 (609.6)	35.00 (889.0)	46.00 (1168.4)	32.13 (816.1)	31.19 (792.2)	22.11 (561.6)	19.36 (491.7)	532 (242)

Dimensions and mounting

Figure 21. Type 3R IntelliPass knockout dimensions

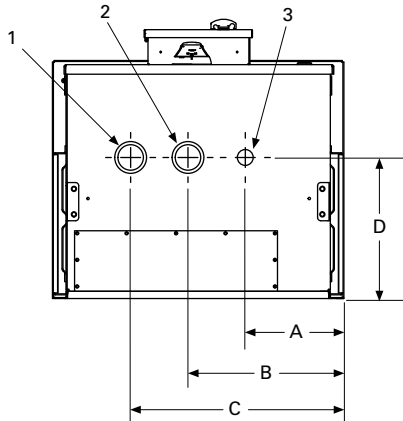

Table 15. Type 3R IntelliPass knockout dimensions

Approximate dimensions in inches (mm)

Enclosure size— drive frame size	A	B	C	D	Conduit 1	Conduit 2	Conduit 3
D1-4	4.06 (103.1)	7.06 (179.3)	10.06 (255.5)	9.62 (244.3)	1.109	1.109	1.375 & 1.109
D1-5	4.06 (103.1)	7.06 (179.3)	10.06 (255.5)	9.62 (244.3)	1.109	1.109	1.375 & 1.109
D2-5	4.06 (103.1)	7.06 (179.3)	10.06 (255.5)	9.62 (244.3)	1.109	1.109	1.375 & 1.109
D3-5	4.06 (103.1)	7.06 (179.3)	10.06 (255.5)	9.62 (244.3)	1.109	1.109	1.375 & 1.109
D3-6	4.06 (103.1)	7.06 (179.3)	10.06 (255.5)	9.62 (244.3)	1.109	1.109	1.375 & 1.109
D4-6	6.06 (153.9)	10.56 (268.2)	15.06 (382.5)	11.13 (282.7)	1.109	1.109	1.984 & 1.109
D4-7	6.06 (153.9)	10.56 (268.2)	15.06 (382.5)	11.13 (282.7)	1.109	1.109	1.984 & 1.109
D4-8	6.06 (153.9)	10.56 (268.2)	15.06 (382.5)	11.13 (282.7)	1.109	1.109	1.984 & 1.109
D5-8	6.06 (153.9)	10.56 (268.2)	15.06 (382.5)	11.13 (282.7)	1.375	2.469 & 1.984	2.469 & 1.984
D6-8	6.06 (153.9)	10.56 (268.2)	15.06 (382.5)	11.13 (282.7)	1.375	2.469 & 1.984	2.469 & 1.984

Figure 22. Type 1 Micro Disconnect dimensions

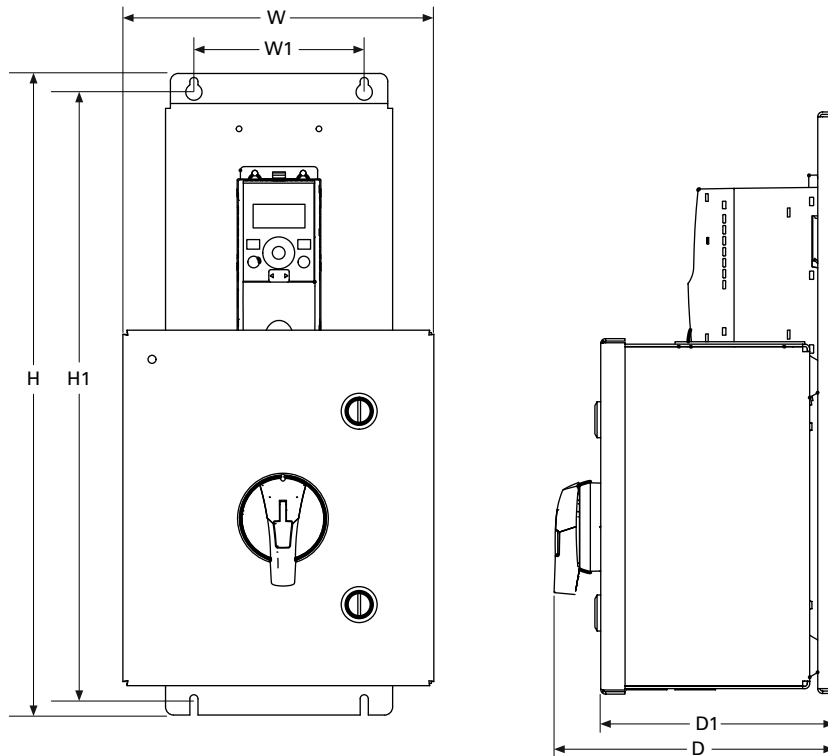

Table 16. Type 1 Micro Disconnect dimensions

Approximate dimensions in inches (mm)

Enclosure size— drive frame size	H	H1	W	W1	D	D1	Weight in lb (kg)
M1-1	19.78 (502.4)	19.03 (483.4)	9.59 (243.6)	5.25 (133.4)	8.61 (218.7)	7.19 (182.6)	13.9 (6.3)
M1-2	19.78 (502.4)	19.03 (483.4)	9.59 (243.6)	5.25 (133.4)	8.61 (218.7)	7.19 (182.6)	15.4 (7.0)

Figure 23. Type 1 Micro Disconnect knockout dimensions

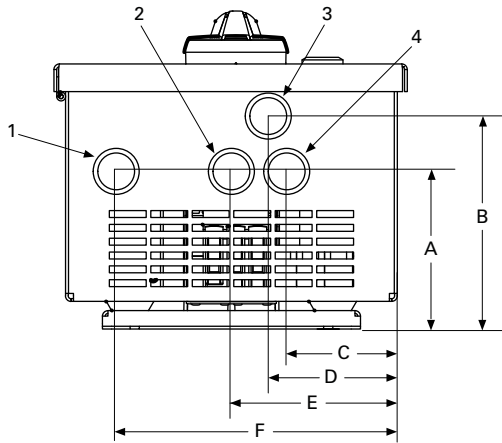

Table 17. Type 1 Micro Disconnect knockout dimensions

Approximate dimensions in inches (mm)

Enclosure size— drive frame size	A	B	C	D	E	F	Conduit 1, 2, 3 & 4
M1-1	4.28 (108.7)	5.78 (146.8)	3.28 (83.3)	3.78 (96.0)	4.78 (121.4)	7.90 (200.7)	1.125 & 0.875
M1-2	4.28 (108.7)	5.78 (146.8)	3.28 (83.3)	3.78 (96.0)	4.78 (121.4)	7.90 (200.7)	1.125 & 0.875

Wiring

Wiring schematic

A schematic is included with each product. The schematic number can be found on the product nameplate.

Typical schematics are shown on the next few pages.

Notes

- Power and motor leads must be in separate conduit
- Do not run control wires in same conduit as input power or motor wires
- Two grounding points are provided, input ground and output ground
- Ground unit properly – improper grounding could damage the unit

Figure 24. Type 1 IntelliDisconnect

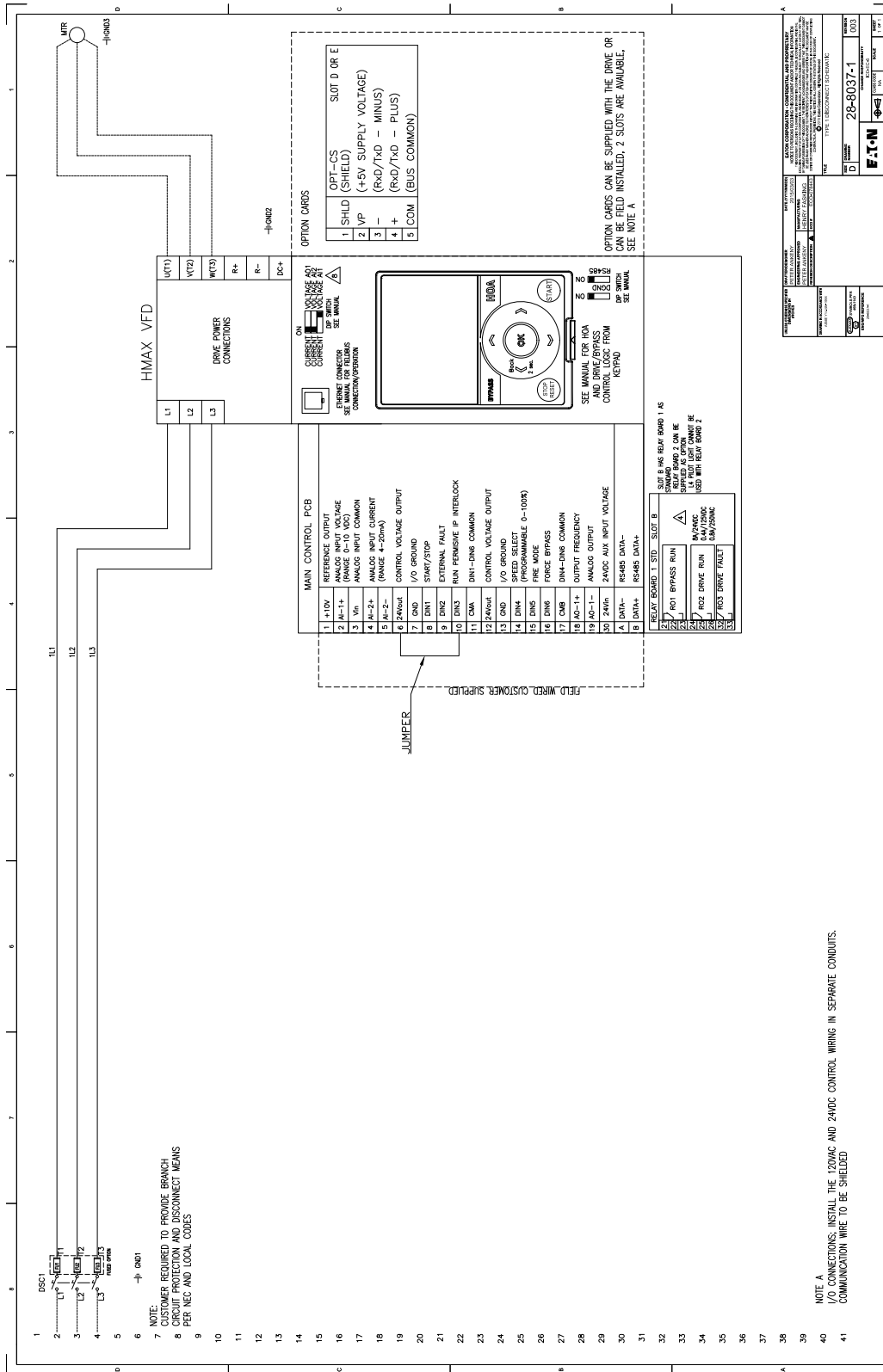

Figure 25. Type 1 IntelliPass

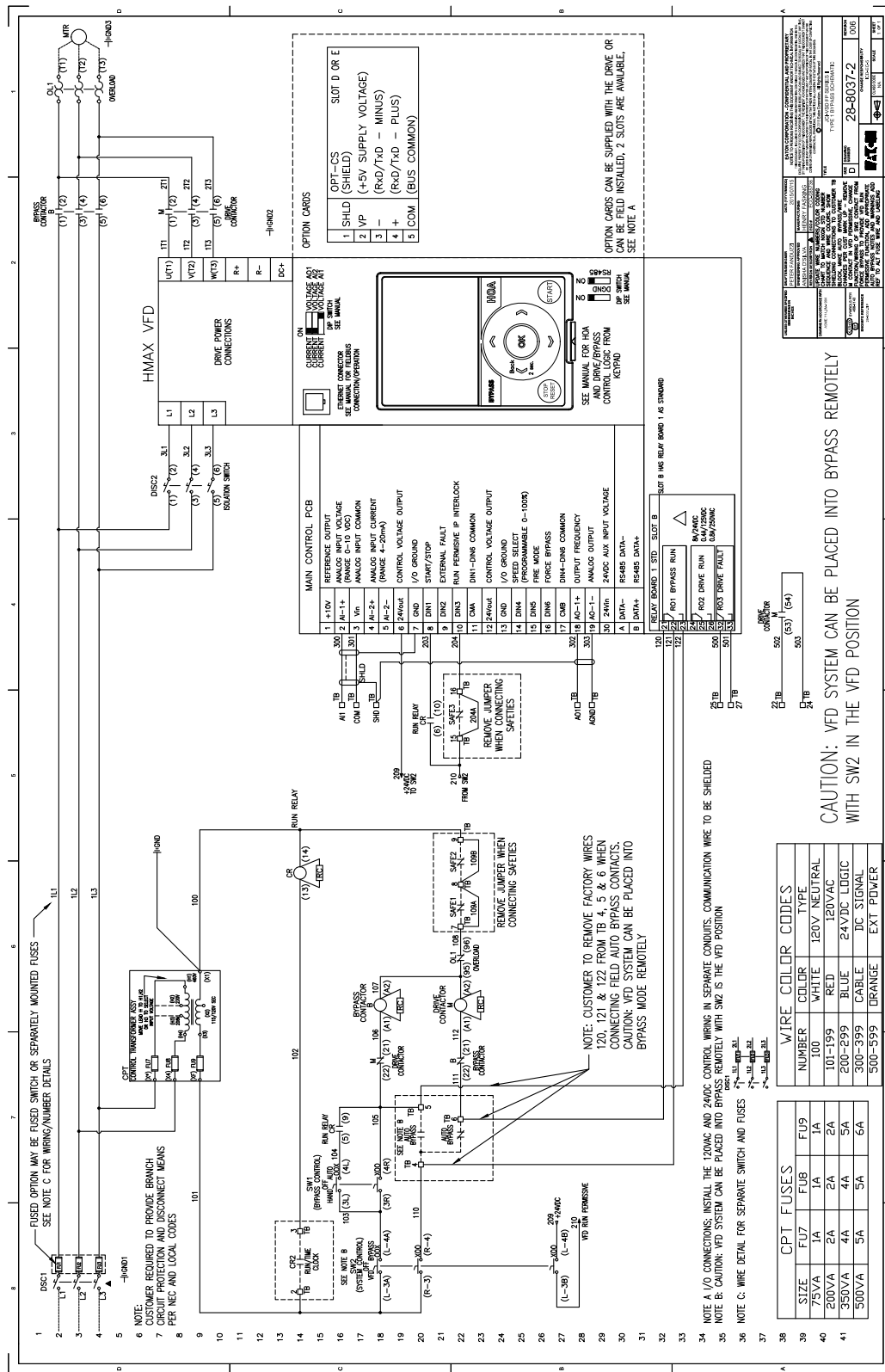

Figure 26. Type 3R IntelliDisconnect

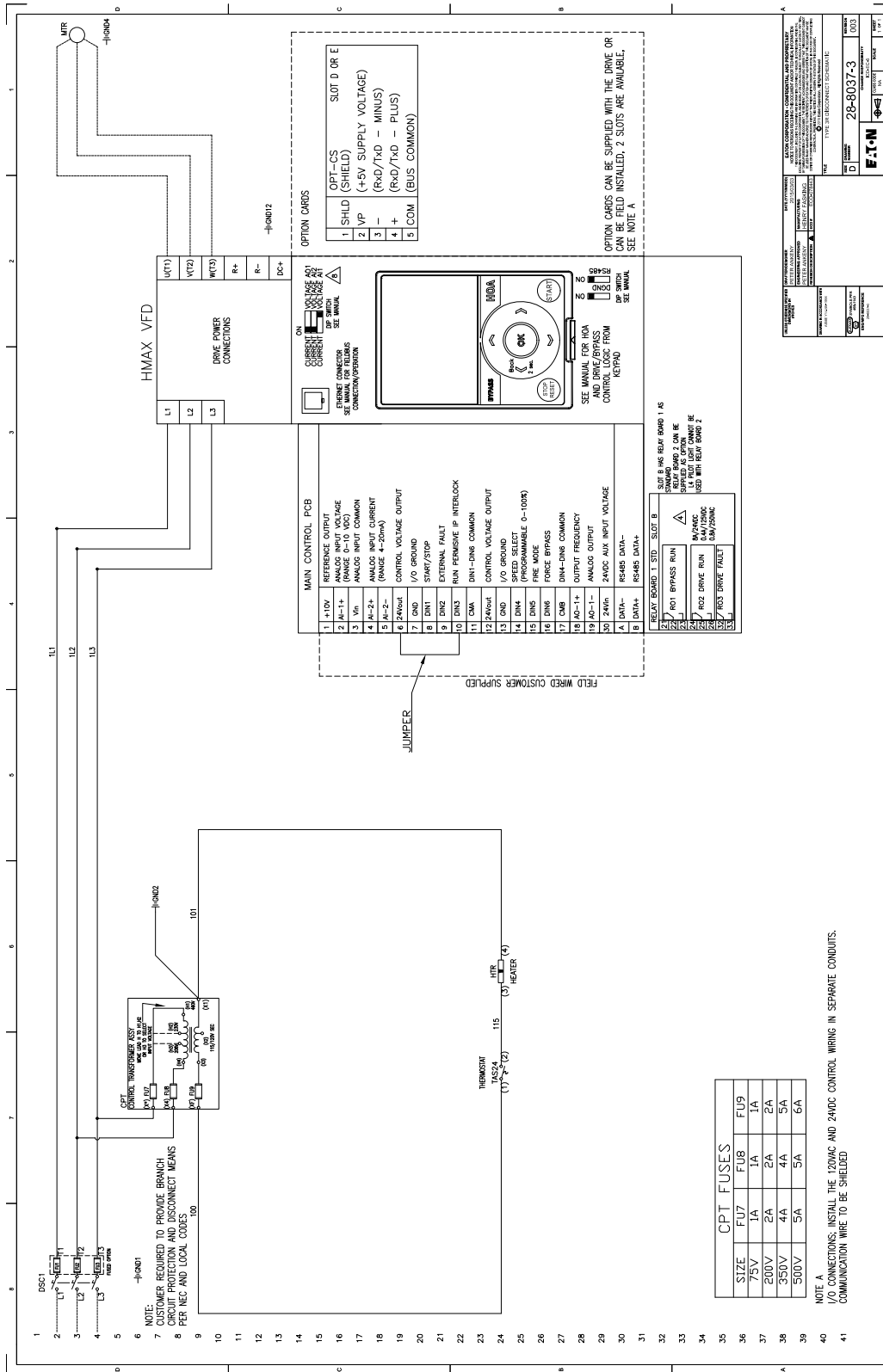
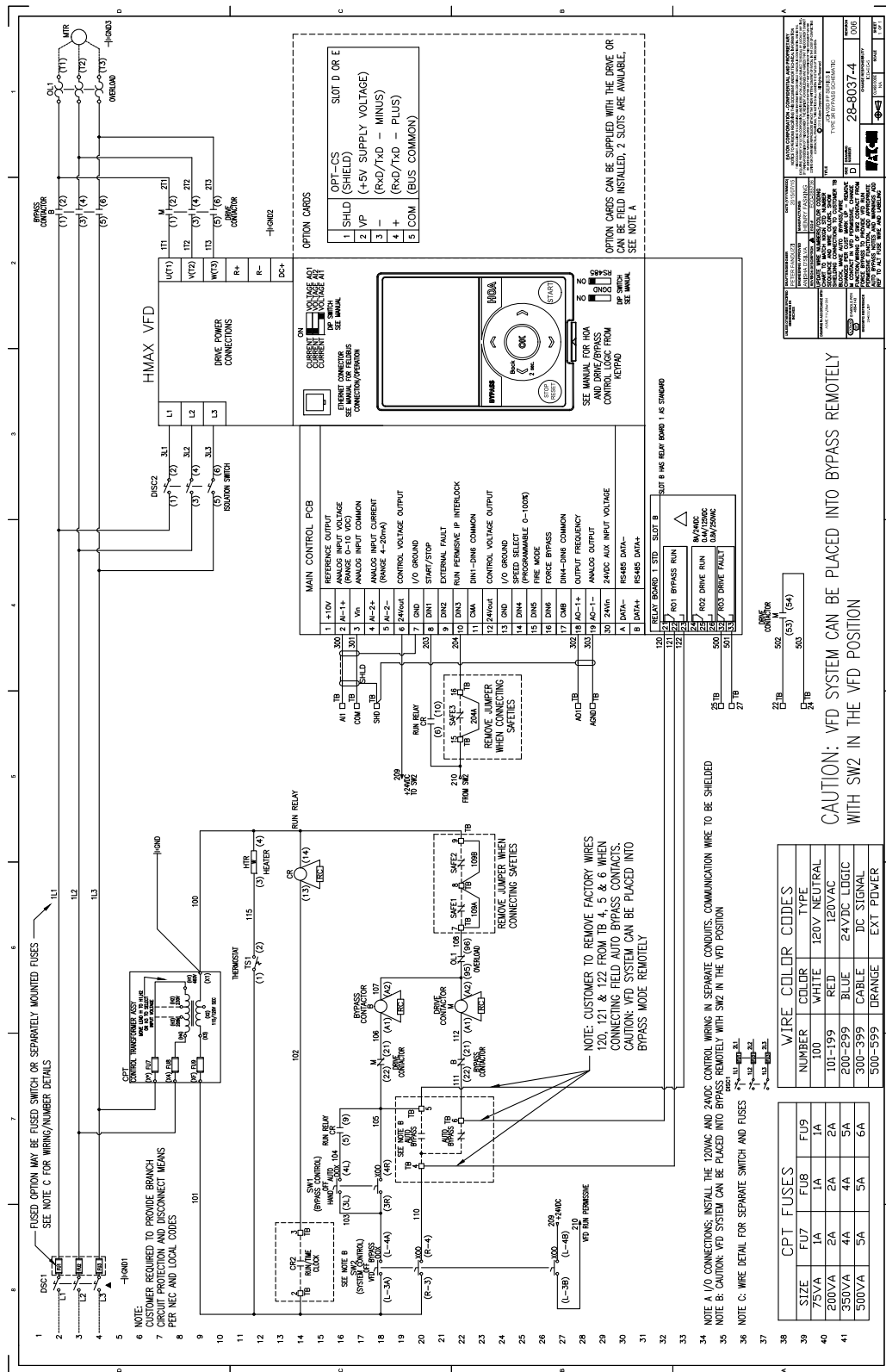

Figure 27. Type 3R IntelliPass



CAUTION: VFD SYSTEM CAN BE PLACED INTO BYPASS REMOTELY WITH SW2 IN THE VFD POSITION

Conduit plates

There are removable top and bottom conduit plates on drives frames size 8 on designations A4, A5, and A6 (Type 1 IntelliDisconnect) configurations to allow for easier wiring and conduit connections.

Input power wiring

Input power connection are made to the disconnect device. Input power connection points are identified by Label (L1, L2, and L3).

Both the IntelliDisconnect and IntelliPass systems provide an input disconnect by using a UL Listed, R9 rotary disconnect fusible or non-fusible as indicated below. These devices provide a disconnect function and branch protection. In non-fusible systems, the disconnect is paired with fused for short circuit protections.

Figure 29. Lower frame incoming lines



Figure 30. Larger frame incoming lines



Input wiring details

Table 18. Input wiring

Voltage	hp	Wire range	Torque (lb-in)
Non-fused disconnect type			
208/230 V	1–5	#14–#10	25
	7.5–10	#14–#10	28
	15–20	#12–2/0	35
	25	#6–300 kcmil	160
	30–40	#6–300 kcmil	160
480 V	1–15	#14–#10	25
	20–30	#14–#10	28
	40–125	#6–300 kcmil	160
Fused disconnect type			
208/230 V	1–5	#14–#10	25
	7.5–10	#14–#10	28
	15–20	#12–2/0	35
	25	#12–#1	35
	30–40	#6–3/0	200
480 V	1–15	#14–#10	25
	20–30	#14–#10	28
	40–125	#6–3/0	200

Motor wiring

Motor connection points are identified by a label (T1, T2, and T3). See output wiring table in technical section for wiring and torque information. For IntelliDisconnect models, the motor wiring is direct to the drive output terminals. For IntelliPass models, the motor wiring is directly to the output of the overload protection relay on the bypass contactor.

Figure 31. IntelliDisconnect motor wiring



Table 19. Output wiring details—IntelliDisconnect

Voltage	hp	Drive frame size	Torque (lb-in)
208/230 V	1–3	4	4.5
	5–10	5	11
	15–20	6	35
	25–30	7	88
	40–50	8	170
480 V	1–7.5	4	4.5
	10–20	5	11
	25–40	6	35
	50–75	7	88
	100–125	8	170
Micro			
208/230/480 V	0.5–2	FS1 / FS2	4.5

Figure 32. IntelliPass motor wiring

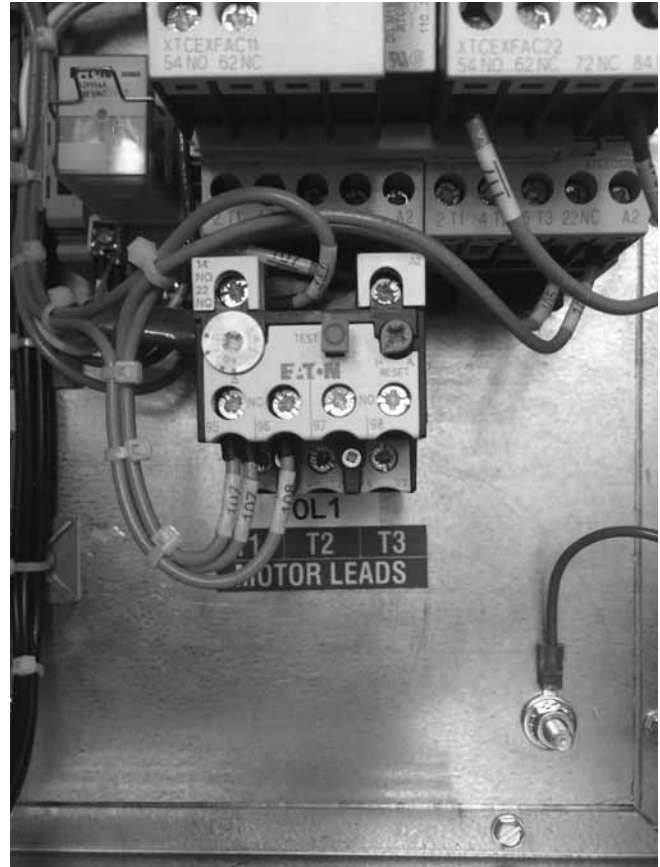

Table 20. Output wiring details—IntelliPass

Voltage	hp	Torque (lb-in)
208/230 V	1–3	15
	5–10	15
	15–20	28
	25–50	90
480 V	1–7.5	15
	10–20	15
	25–40	28
	50–125	90

Ground wiring

Ground studs are provided and marked with label. Hardware is also supplied.

Figure 33. Typical ground stud and label



Frames 1 through 5 have ground lugs supplied for wire size 14 to 2/0.

Frame 6 with drive frame size 8 has ground lugs supplied for wire size 3/0.

Control wiring

All customer wiring points are supplied on a terminal block strip. This terminal strip allows easy access to the drives control terminals and auxiliary contacts. The control I/O terminals must be tightened to 4.5 lb (0.5 Nm). Please see table below for terminal block designation.

Figure 34. Terminal block access

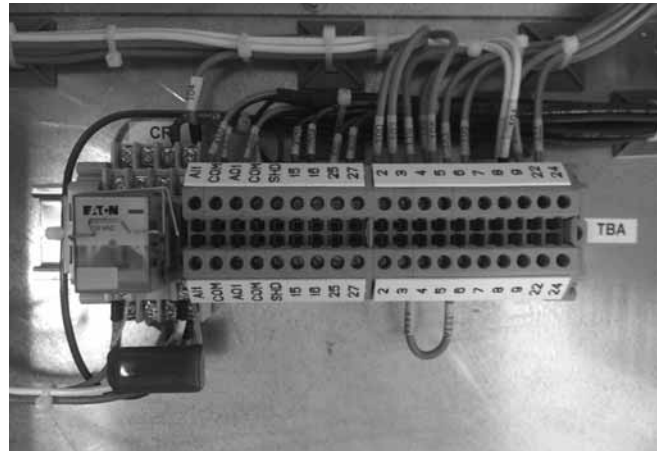

Table 21. Terminal block designation

Terminal block	Description
AI1	Analog Input Voltage (Range 0–10 Vdc)–2
COM	Analog Input Common–3
A01	Output Frequency–18
COM (AGND)	Analog Output–19
SHD	GND–7
15	Safety 3
16	Safety 3–Run Permissive IP Interlock–10
25	RO3 Drive Fault Output–32
27	RO3 Drive Fault Output–33
2	Run/Time Clock Start/Stop Command
3	Run/Time Clock Start/Stop Command
4	Electronic Bypass connection points
5	Electronic Bypass connection points
6	Electronic Bypass connection points
7	Safety 1 and 2 connection points
8	Safety 1 and 2 connection points
9	Safety 1 and 2 connection points
22	Drive Contactor (Run Output)–53
24	Drive Contactor (Run Output)–54

Initial startup

When the IntelliPass or IntelliDisconnect is first powered up, the Startup Wizard command should be displayed.

Figure 35. Startup Wizard prompt

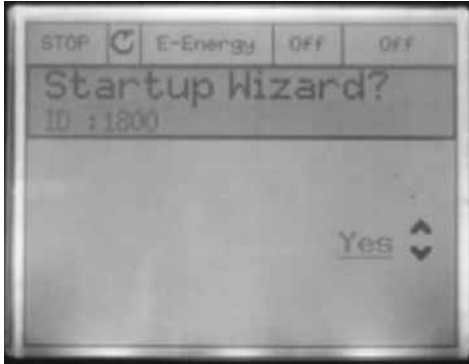

Follow the Quick Setup guide LIT-12011773 to set up drive for your specific application with the following exceptions: When the Bypass screen appears, set it to “Enabled” for IntelliPass models and “Disabled” for IntelliDisconnect models.

Figure 36. Enable bypass for IntelliPass models

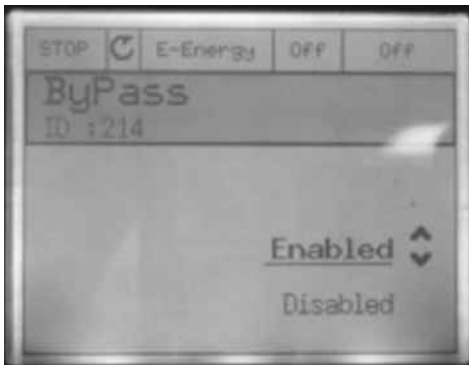
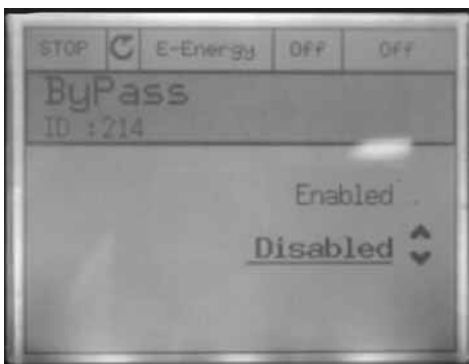

Figure 37. Disable bypass for IntelliPass models



IntelliDisconnect operation (starting/stopping of the motor)

IntelliDisconnect operation is identical to a standard JCI-VSD Series II open drive. The only difference is that an input disconnect is provided. For more information on speed control and other drive features, see Application Manual LIT-12011771. See option sections for more information on operation of IntelliDisconnect options, i.e., drive output contactor.

IntelliPass operation (starting/stopping of the motor)

The IntelliPass operation is similar to the IntelliDisconnect but has the added feature of a built-in drive bypass. This section gives basic information on operations for controlling the starting and stopping of the motor in both the drive and bypass modes. For more information on speed control and other drive features, see Application Manual LIT-12011771.

The IntelliPass has 2 modes:

- Drive mode (normal VFD operation)
- Bypass mode (across the line)

The mode is selected via the keypad. The actual starting and stopping of the motor is determined by the HOA selection and the control place selections. The control place is defined as the location from where the drive is started and stopped. The control place can be: keypad start button, I/O contacts wired to the logic terminal blocks, Fieldbus control or PC. See Quick Start Guide LIT-12011775 or Application Manual LIT-12011771 for more information.

The only exception is the use of the drive—bypass 3-position switch for manual operation. This will override the drive logic and can start the motor in Bypass immediately.

Switch operation

HOA switch

Auto position = the drive will follow a run command from the runtime clock wired to terminal block 2 and 3.

Hand position = this will force a run command to the drive. This is true in both bypass and drive mode.

VFD- OFF-BYP

VFD position = the drive will run in normal drive operation.

BYP position = the drive will go into bypass mode. The bypass contactor will close and the drive contactor will open.

When in the VFD position, the bypass can be selected electronically from the keypad or from external communications such as SA Bus.

Drive mode

When the IntelliPass is in the drive mode, the text “E-Energy” is shown on status bar. (If E-Energy function is not active, the text “Ready” will be shown.)

Figure 38. Keypad shown in drive mode

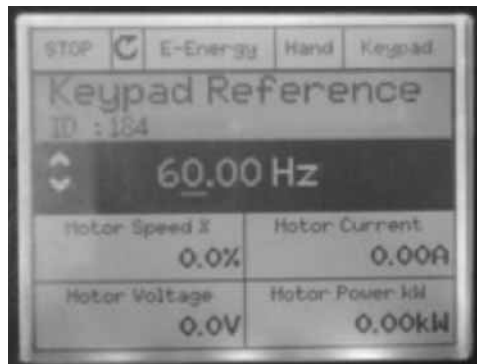

When the system is first commanded to run, the output contactor M is energized and the motor is connected to the drive. The “M” contactor is controlled by the IntelliPass logic via Relay 2 output. The “M” contactor will always be energized while the VFD-OFF-BYP switch is in the VFD position unless the bypass command is electronic. The speed of the motor is determined by the speed set point of the JCI-VSD Series II Drive. When the JCI-VSD Series II is commanded to stop, the drive will reduce the speed of the motor and when the motor speed reaches zero, the output contactor “M” is de-energized and the motor is disconnected from the IntelliPass. The output contactor also opens immediately if there is a drive fault.

The IntelliPass system is also interlocked. When the output contact “M” is energized, the bypass contactor “B” is prevented from being energized by electrical interlocks in each contactor coil control circuit and a logic interlock built in to the IntelliPass software.

Bypass mode

When the IntelliPass is in the bypass mode, the text “Bypass” is shown on status bar. When bypass is selected electronically, if selected via the VFD-OFF-BYP switch, the drive will not be ready. “E-Energy” will be flashing.

Figure 39. Keypad shown in bypass mode



When the system is commanded to run in the bypass mode, the motor is connected to the line through the bypass contactor (B). The “B” contactor is controlled by the drive logic via a Relay 1 output.

The bypass mode can be selected in 3 ways:

- Manually via the drive logic controls (i.e., keypad, fieldbus, or I/O)
- Automatically after a drive fault; if the auto bypass feature is active
- Manually by a door switch; manually using the manual bypass switch

Initial startup

Manual bypass

Manual bypass can be activated either by using the bypass button on the keypad, by using a digital input on the control terminal block or from the fieldbus. The user can toggle between bypass and drive modes by pressing the keypad bypass button or the terminal block inputs. Once in the bypass mode, the start command can be given through any control place (I/O, keypad, and fieldbus) in the same manner as starting in the drive mode.

Using the keypad to select bypass mode

When the bypass button is pressed, the following options are shown to the user. Select the desired mode by using the arrow keys and pressing the OK key.

Figure 40. Keypad with bypass and drive mode option

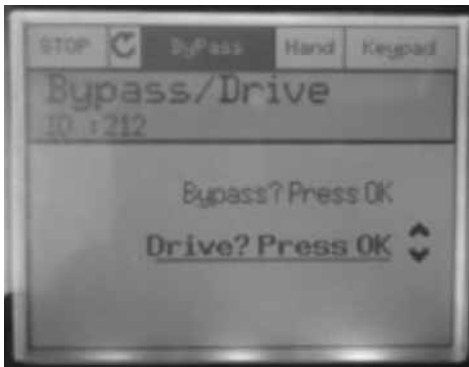

The user can toggle between modes by pressing the bypass button again. If bypass button is pressed while the drive is running, the keypad will display "Bypass is not allowed". The system must be stopped to allow a change from drive to bypass mode. Likewise if the system is running in bypass and the bypass key is pressed, the display will indicate "Motor Running in Bypass." To change state back to drive, the system must be stopped. The keypad will display bypass in the status display when in the bypass mode and ready or E-Energy when in the drive mode.

Figure 41. Keypad shown in run mode

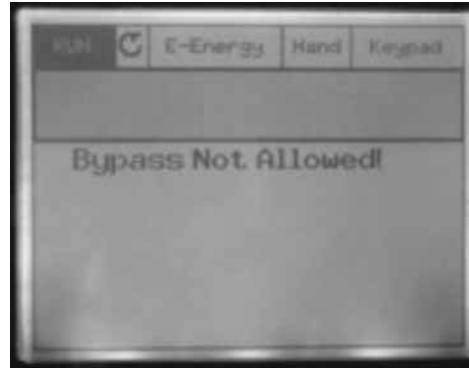
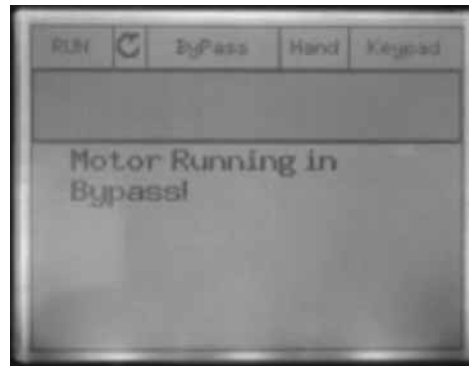

Figure 42. Keypad already in bypass mode



Using the digital input to select bypass mode

If the digital input (Force Bypass) is used to enable the bypass mode, the drive will ramp to zero speed. Once the drive stops, the bypass mode is active and the keypad will display the bypass mode. The bypass and motor will start when a valid start command is received. Note that the Force Bypass function is the factory default for Digital Input #6 P2.3.6.2 located at TB16 on the control module and is also factory wired to the M1 Manual Bypass option if supplied.

Using the fieldbus to select bypass mode

The fieldbus command works the same as the digital input.

Auto bypass operation

The drive can also be bypassed automatically if certain faults occur. When the selected fault occurs, the drive is first stopped. Then, depending on the automatic reset parameter, the drive is either bypassed instantly or the fault is first tried to reset. If the reset fails, the motor is automatically started in bypass.

Figure 43. Parameter menu for automatic reset

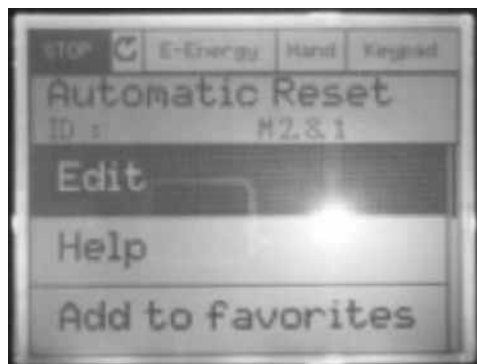

Figure 44. Menu selecting auto bypass

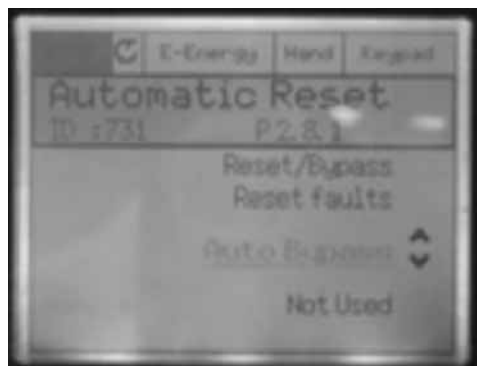
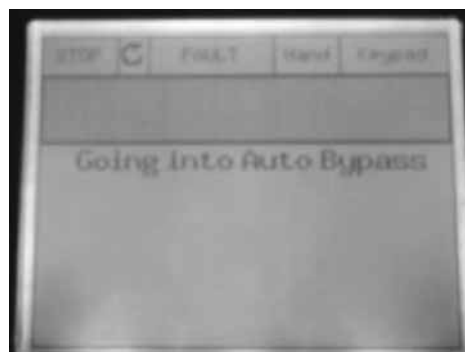

Figure 45. Menu selecting reset/bypass



When the drive goes to auto bypass, the keypad displays “Going into Auto Bypass” for 10 seconds. After the delay, the drive goes to the bypass mode and starts the motor (the run command must still be present). When the fault condition is not active, the drive is set back to drive mode automatically and the bypass running signal is reset. The drive returns to the normal operation.

Figure 46. Displaying going into auto bypass after fault



Automatic reset selections

- 0 = Not used
- 1 = Auto Bypass (Visible only if Bypass is enabled)
- 2 = Reset faults
- 3 = Reset/Bypass (Visible only if Bypass is enabled)

Initial startup

Activate the automatic reset functions with this parameter

For option 1, if the drive faults, the drive switches automatically to bypass and leaves the fault active on the drive. For option 3, the drive will first try to auto reset the faults but if not successful, it will then switch to bypass. Option 2 just tries to reset the fault without going into bypass. See the application manual for more information on auto reset operation.

Manual bypass (forced)

The IntelliPass also has a forced manual bypass option. This is controlled by a door mounted Drive / Off / Bypass switch. The door switch will start the motor in bypass following the HOA switch run commands. Switch to the Hand position to start bypass immediately. This switch manually overrides the system (keypad) and forces the unit into bypass mode even if the drive is in operative or removed from the system.

HOA control

The keypad HOA button is used for fast and easy changing between Hand, Off and Auto control places to change the speed set point source. HOA control works in both the drive and bypass modes of operation. However, speed set point has no functions when in bypass because the motor runs full speed across the line. The drive should remain in Auto mode during normal operation.

Figure 47. Hand/Off/Auto parameter

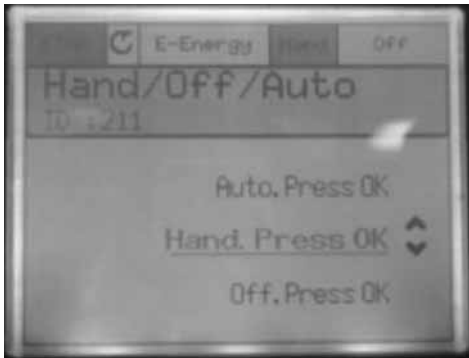

Control place is defined as the location from where the drive or bypass is started and stopped. Hand and auto are two different control places.

There are four parameters for selecting a control source and reference source for them: P2.1.3 HOA Control Source, P2.1.4 Start Source Hand, P2.1.5 Speed Set point Hand, P2.1.6 Start Source Auto & P2.1.7 Speed Set point Auto. The Start Source selections are: Keypad, I/O Terminal, I/O 3-wire & Fieldbus Ctrl. For the drive mode, the Speed set point the selections are: Keypad Ref, Fieldbus, AI1, AI2, AI1+AI2, & PID1 (if PID is activated). See Quick Start Guide LIT-12011773 or Application Manual LIT-12011771 for more information.

When control place Off is selected, the drive cannot be started anywhere. It prohibits the start command for both drive and bypass. Bypass may force started in the HOA off mode by using the door switch.

Figure 48. Off menu selection



Figure 49. Monitoring menu in STOP mode



Key parameters related to proper IntelliPass bypass operation

The following parameters are related to Bypass functionality and are factory default set. Changing them will affect proper IntelliPass operation.

- P2.1.2 Bypass: This parameter is for activating the bypass functionality. It is factory enabled. If disabled, the Bypass keypad button is inactive and some parameters may be hidden. This is part of the Startup Wizard.
- P2.3.2.2.1 (RO1 Function) set to Bypass Run. This signal is active if the bypass mode has been selected and the run command is active—this relay output controls the bypass contactor it should not be changed.
- P2.3.2.2.5 (RO2 Function) set to Run. This signal is active if the drive mode has been selected and the run command is active—this relay output controls the output contactor and should not be changed.

SA bus operation and setup

Wiring SA bus

Wire the SA bus as shown below.

If this is the last device on the line, set the X4 termination resistor to ON.

Table 22. SA bus setup

SA bus terminal	Wire	Color
3	SA-	Black
4	SA+	Blue
5	Common	White
N/C	SA Power	Red

Figure 50. JC-VSD Series II drive SA bus interface card VS-XXM-CS

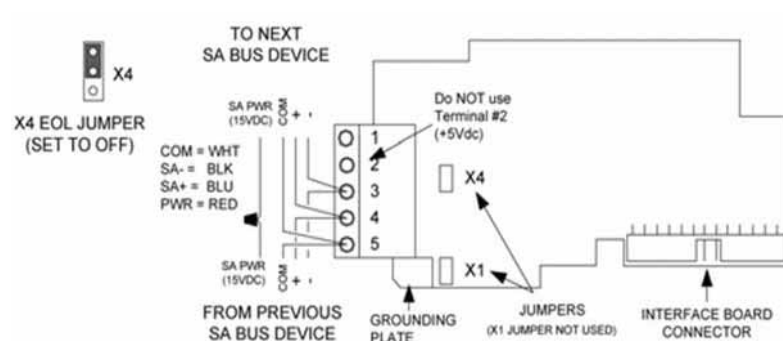

Initial startup

Programming

1. Ensure the correct fieldbus protocol is selected.
 - a. Navigate: P4.4.3.1
 - b. Main Menu → I/O Hardware → OPTCS → Parameters → Comm. Protocol

STOP	<input checked="" type="checkbox"/>	E-Energy	OFF	OFF	STOP	<input checked="" type="checkbox"/>	E-Energy	OFF	OFF	STOP	<input checked="" type="checkbox"/>	E-Energy	OFF	OFF	STOP	<input checked="" type="checkbox"/>	E-Energy	OFF	OFF
Main Menu ID : M4					I/O and Hardware ID : M4.4					OPTCS ID : M4.4.3					Parameters ID : P4.4.3.1				
Diagnostics					Basic IO					Monitor					Comm. Protocol SA Bus				
I/O and Hardware					Slot D					Parameters					Slave address 1				
User Settings					OPTCS					Software Info					Comm. Timeout 10 s				

2. Set the slave address.
 - a. Navigate: P4.4.3.2
 - b. Main Menu → I/O Hardware → OPTCS → Parameters → Slave Address

STOP	<input checked="" type="checkbox"/>	E-Energy	OFF	OFF	STOP	<input checked="" type="checkbox"/>	E-Energy	OFF	OFF	STOP	<input checked="" type="checkbox"/>	E-Energy	OFF	OFF	STOP	<input checked="" type="checkbox"/>	E-Energy	OFF	OFF
Main Menu ID : M4					I/O and Hardware ID : M4.4					OPTCS ID : M4.4.3					Parameters ID : P4.4.3.2				
Diagnostics					Basic IO					Monitor					Comm. Protocol SA Bus				
I/O and Hardware					Slot D					Parameters					Slave address 1				
User Settings					OPTCS					Software Info					Comm. Timeout 10 s				

3. Set the Start Source Auto to "Fieldbus."
 - a. Navigate: P2.1.6
 - b. Main Menu → Parameters → Basic Parameters → StartSourceAuto

STOP	<input checked="" type="checkbox"/>	E-Energy	OFF	OFF	STOP	<input checked="" type="checkbox"/>	E-Energy	OFF	OFF	STOP	<input checked="" type="checkbox"/>	E-Energy	OFF	OFF
Main Menu ID : M2					Parameters ID : M2.1					Basic Parameters ID :1302 P2.1.6				
Monitor					Basic Parameters					StartSourceHand Keypad				
Parameters					Analog Inputs					SpeedSetptHand Keypad Ref				
Diagnostics					Digital Inputs					StartSourceAuto FieldbusCTRL				

4. Set the Speed Set Point Auto to "Fieldbus."
 - a. Navigate: P2.1.7
 - b. Main Menu → Parameters → Basic Parameters → SpeedSetptAuto

STOP	<input checked="" type="checkbox"/>	E-Energy	OFF	OFF	STOP	<input checked="" type="checkbox"/>	E-Energy	OFF	OFF	STOP	<input checked="" type="checkbox"/>	E-Energy	OFF	OFF
Main Menu ID : M2					Parameters ID : M2.1					Basic Parameters ID :1303 P2.1.7				
Monitor					Basic Parameters					SpeedSetptHand Keypad Ref				
Parameters					Analog Inputs					StartSourceAuto FieldbusCTRL				
Diagnostics					Digital Inputs					SpeedSetptAuto Fieldbus				

Control

1. To run the VSD in drive mode, write a 1 to VSD-C and a speed reference in percent to VSD-O.
2. To run in bypass mode, write a 1 to VSD-BYPASS and a 1 to VSD-C.

Table 23. Object list

Object name	Object description	Port function	NetDeviceRefAttrID	I/O	Units	States text	Set members
VSD-C	VSD Command	Run/Stop	Drive Command	Output		Off/On	0=Off, 1=On
VSD-O	VSD Output	Output	Reference Command	Output	%		
VSD-S	VSD Status	Status	Drive Running	Input		Off/On	0=Off, 1=On
VSD-BYPASS	VSD Bypass Drive	Bypass Enable	Bypass Enable	Output		Inactive/Active	0=Inactive, 1=Active
VSD-RESET	VSD Reset Drive Fault	Reset Drive Fault	Reset Drive Fault	Output		Off/Reset	0=Off, 1=Reset
VSD-KWH	VSD Kilowatt Hours	Kilowatt Hours	Kilowatt Hours	Input	kWh		
VSD-SPEED	VSD Motor Speed	Motor Speed	Motor Speed	Input	rpm		
VSD-FREQ	VSD Output Frequency	Frequency	Output Frequency	Input	Hz		
VSD-%	VSD Speed Feedback	Speed Setpoint	Speed Setpoint	Input	%		
VSD-HOA	VSD Control Mode	Control Mode	Control Mode	Input		Hand Off Auto	0=Hand, 1=Off, 2=Auto
VSD-FAULT	VSD Fault Code	Fault Code	Fault Code	Input		Drive Fault	0=No Fault 1=Over Current 2=Over Voltage 3=Ground Fault 4=Bypass Overload 5=Charging Switch 6=Emergency Stop 7=Saturation Trip 8=System Fault 9=Under Voltage 10=Input Line Supervision 11=Output Phase Supervision 12=System Fault 13=Drive Heatsink Under Temp 14=Drive Heatsink Over Temp 15=Motor Stalled 16=Motor Overload Temp 17=Motor Underload 18=External Fault 19=Comm Bus Fault 20=Drive Fault

IntelliPass/IntelliDisconnect technical information

See JCI-VSD Series II Installation Manual LIT-12011775 for additional data.

- Enclosure: Type 1 or Type 3R as ordered
- Max. Ambient Temp: 40 °C
- Wire temperature rating of field installed conductors: use 75 °C copper conductors only

Table 24. Short-circuit rating

Frame	Voltage	Available current
4–8	208 Vac, 280 Vac, 480/277 Vac	100,000 A

Additional help

Website address

www.johnsoncontrols.com → HVAC Controls → Variable Speed Drives

Johnson Controls product sales operation

Call the Johnson Controls PSO Team if you need assistance with placing an order, stock availability or proof of shipment, expediting an existing order, emergency shipments, product price information and returns (including warranty returns).

Voice: 1-800-ASK-JNSN [275-5676] (US); 1-800-321-4023 (CA)

FAX: 1-800-356-1191 (US); 1-800-321-4024 (CA)

Support Hours of Operation: Monday–Friday, 6:30 a.m.–5:30 p.m. CST
(No evening or weekend Customer Service hours)

If you are in the U.S. or Canada, you can take advantage of our toll-free line for technical assistance. Technical support engineers are available for calls during regular business hours.

Johnson Controls Field Support Center
1-888-281-3792 Monday–Friday, 7:30 a.m.–5:30 p.m. CST
email:CGFieldSupportCenter@jci.com

Powered by Eaton Technology

Controls Group
507 E Michigan Street
PO Box 423
Milwaukee, WI 53201

© 2015 Johnson Controls
All Rights Reserved
Publication No. LIT-12012114 / Z16866
July 2015

All trademarks are property of their
respective owners.

